

# Advanced turboprop multidisciplinary design and optimization within AGILE project

Pierluigi Della Vecchia<sup>\*</sup>, Luca Stingo<sup>†</sup>, Fabrizio Nicolosi<sup>‡</sup>, Agostino De Marco<sup>§</sup>,

University of Naples Federico II, ITALY

Giovanni Cerino<sup>\*\*</sup>

LEONARDO, Aircraft Division, ITALY

Pier Davide Ciampa<sup>††</sup>, Prajwal Shiva Prakasha<sup>‡‡</sup>

DLR, German Aerospace Center, GERMANY

Marco Fioriti<sup>§§</sup>

Politecnico di Torino, ITALY

Mengmeng Zhang<sup>\*\*\*</sup>

AIRINNOVA AB, Stockholm, SWEDEN

Artur Mirzoyan<sup>†††</sup>

CIAM, Moscow, RUSSIA

Benedikt Aigner<sup>‡‡‡</sup>

ILR, RWTH Aachen University, GERMANY

Dominique Charbonnier<sup>§§§</sup>

CFS Engineering, SWITZERLAND

The present paper deals with the design, analysis and optimization of a 90 passengers turboprop aircraft with a design range of 1200 nautical miles and a cruise Mach number equal to 0.56. The prescribed aircraft is one of the use cases of the AGILE European project, aiming to provide a 3<sup>rd</sup> generation of multidisciplinary design and optimization chain, following the collaborative and remote aircraft design paradigm, through an heterogenous team of experts. The multidisciplinary aircraft design analysis is set-up involving tools provided by AGILE partners distributed worldwide and run locally from partners side. A complete design of experiment, focused on wing planform variables, is performed to build response surfaces suitable for optimization purposes. The goal of the optimization is the direct operating cost, subject to wing design variables and top-level aircraft requirements.

---

<sup>\*</sup> Assistant Professor, Department of Industrial Engineering (DII), AIAA member

<sup>†</sup> PhD Student, Department of Industrial Engineering (DII)

<sup>‡</sup> Associate Professor, Department of Industrial Engineering (DII), AIAA member

<sup>§</sup> Assistant Professor, Department of Industrial Engineering (DII), AIAA member

<sup>\*\*</sup> Civil transport aircraft preliminary design coordinator

<sup>††</sup> Research Scientist, Air Transportation Systems Institute, Hamburg, AIAA member

<sup>‡‡</sup> Research Scientist, Air Transportation Systems Institute, Hamburg, AIAA member

<sup>§§</sup> Assistant Professor, Aerospace Department (DIMEAS), AIAA Member

<sup>\*\*\*</sup> Research Scientist, AIAA member

<sup>†††</sup> Head of Department, Moscow, AIAA member

<sup>‡‡‡</sup> Researcher, AIAA member

<sup>§§§</sup> Researcher, AIAA member

## I. Nomenclature

CPACS	=	common parametric aircraft configuration schema
CO <sub>2</sub>	=	carbon dioxide
CS2	=	clean sky 2
DOC	=	direct operating costs
DOE	=	design of experiments
HiFi	=	high fidelity
LNFL	=	landing field length
LoFi	=	low fidelity
MDAO	=	multidisciplinary design analysis and optimization
MTOW	=	maximum takeoff weight
OBS	=	on board systems
RCE	=	remote control environment
RM	=	rear engine mounted configuration
SF	=	engine scale factor
SF <sub>w</sub>	=	wing chords scale factor
TOFL	=	take-off field length
TLAR	=	top level aircraft requirements
WM	=	wing engine mounted configuration
b	=	span
c	=	chord
C <sub>Dflap</sub>	=	drag coefficient contribution due to flaps deflection
C <sub>Lmax</sub>	=	maximum lift coefficient
C <sub>Mflap</sub>	=	pitching moment coefficient contribution due to flaps deflection
d	=	diameter
(·) <sub>f</sub>	=	fuselage
(·) <sub>k</sub>	=	kink
L	=	length
mac	=	mean aerodynamic chord
(·) <sub>LE</sub>	=	leading edge
(·) <sub>r</sub>	=	root
(·) <sub>t</sub>	=	tip
(·) <sub>w</sub>	=	wing
λ	=	taper ratio
Λ	=	sweep angle
Γ	=	dihedral angle

## II. Introduction

The present paper deals with the multidisciplinary design, analyses and optimization of a 90 passengers regional turboprop aircraft, capable to cover a range of 1200 nautical miles, within the AGILE European project. The AGILE project (*Aircraft 3<sup>rd</sup> Generation MDO for Innovative Collaboration of Heterogeneous Teams of Experts*), is an European Union funded project, through the project HORIZON 2020, coordinated by the DLR, [1][2], and it aims to create an evolution of Multi-Disciplinary aircraft Optimization (MDO), promoting a novel approach based on collaborative remote design and knowledge dissemination among various teams of experts.

Main AGILE goals are related to i) the development of an advanced MDO technique in order to reduce convergence time and to face the lack of knowledge about how optimization workflows involving a lot of disciplines; ii) the development of processes and techniques for efficient multisite collaboration in the overall design teams; iii) involve companies, research centers and universities in order to better understand results deriving from several disciplines and share their best competencies and experiences to foster Collaborative, Remote and Distribute aircraft design approach; iv) develop and publish an Open MDO Test Suite, allowing the open access to the project, providing a reference database for the future aircraft design. The project duration is 3 years: during the 1<sup>st</sup> year, a reference distributed MDO system has been formulated and applied on a typical regional jet aircraft, using tools and methodologies available within AGILE consortium [3][4]. In the second year several knowledge enablers [5][6],

optimization techniques improvements [7][8] and visualization packages[9] have developed and tested to enrich and speed-up the whole design and optimization process.

The last year of the project aims to show the capability of the developed technologies, through the applications of MDO to six different aircraft architectures: i) struct-braced, ii) box-wing, iii) blended wing body iv) innovative propulsion system, v) unmanned vi) advanced turboprop, which deals with the present paper. Two different turboprop aircraft architectures are considered: 1) a wing engine mounted (WM) configuration and 2) a rear engine mounted (RM) configuration. Whole design and optimization process involves a heterogeneous team of experts, which cooperates to accomplish with the task. An architect releases the top-level aircraft requirements (TLARs) and the main objective of the design, in this case LEONARDO design office; then an integrator (UNINA), together with the architect, select from a catalogue, all the disciplines need to accomplish with the prescribed task. A set of disciplines is hence entrusted to a group of discipline specialists, distributed worldwide, which have in charge for solving an item (aerodynamic, structure, systems and so on) via remote control.

The entire process, from the TLAR until whole MDAO, is implemented in a chain developed within AGILE project, named KE-Chain [9] through which is possible to build up the workflow step by step. In the first steps the architect and the integrator can insert the TLAR and information about all the participants involved in the specific task, upload the common aircraft definition file and tools chosen from the catalogue. Following, the specialists add input and output file related to their own tools and the integrator assembles the chain as an MDA, DOE or MDO choosing which variables will be considered as design, constraints or objective variables. The remote, collaborative and distributed design is achieved by the using of a specific software named BRICS [11][12] which allows, through a standard communication mechanism, each specialist to run his own tool locally and shared the results automatically. Results are collected from integrator and judged together with architect. Whole process is automatized, performed in remote and collaborative manner, highlighting the high flexibility of the AGILE framework, so called AGILE symphony, as shown in Fig. 1.

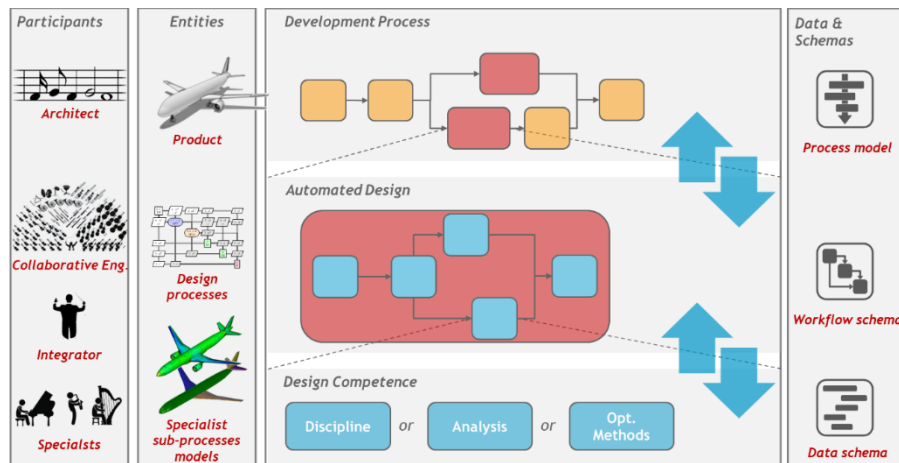

**Fig. 1 AGILE project symphony.**

UNINA leads the design, analysis and optimization of innovative turboprop platform as task leader of the project. During the last three decades, many experiences have been carried out on the numerical and experimental aerodynamic design and analysis [13][14][15][16]. The UNINA team gained experience in design and optimization of regional turboprop aircraft [17][18][19]. Reliable design methodologies have been developed through numerical and experimental tests [20][21], and applied to the design and analysis of light and general aviation aircraft [22][23][24]. Moreover, all the methodologies are integrated within a stand-alone Java library, developed for the design and optimization of transport aircraft [25][26].

In the present paper the WM configuration (wing mounted engine) design and optimization is presented, focusing on the MDAO methodologies developed during the AGILE project. Sec. III introduces the aircraft TLAR and the baseline initialization. In Sec. IV the overall workflow is presented and the strategy for design, analysis and optimization is described. Finally, results are presented in Sec. V and conclusions addressed.

### III. Aircraft initialization

The top-level aircraft requirements (TLAR) have been provided by LEONARDO company and are summarized in Table I. The aircraft must be a turbopropeller aircraft capable to cover 1200 nautical miles with 90 passengers. The cruise Mach number must be equal to 0.56 at flight level 25000 ft. Take-off and landing field lengths must be lower than 1500 meters respectively. The aircraft configuration for the WM must be a high-wing T-tail configuration. The design objective function must be the direct operating cost.

**Table I: Regional TurboProp Aircraft TLARs provided by LEONARDO Company.**

	<b>Metric</b>	<b>Imperial</b>
<b>Design Range</b>	2222.4 km	≥1200 nm
<b>Design payload</b>	9540 kg	21032 lbs
<b>Max. payload</b>	11590 kg	25552 lbs
<b>PAX</b>	90 pax @ 106 kg	90 pax @ 233.7 lbs
<b>MLW (% MTOW)</b>	97% MTOW	
<b>Cruise Mach (LRC)</b>	0.56 @ 7620 m	0.56 @ 25000 ft
<b>Maximum Operating Altitude</b>	7620 m	25000 ft
<b>Climb Time (1500 ft to 200 FL)</b>	13 min	
<b>TOFL (ISA, SL, MTOW)</b>	≤1500 m	4920 ft
<b>Landing distance</b>	≤1500 m	4920 ft
<b>Max. operation speed (Vmo / Mmo)</b>	270kcas/Mach 0.60	
<b>Dive Mach number (Md)</b>	0,64 Mach	
<b>Fuselage diameter</b>	3.53 m – 5 abreast	139,17 in 5 abreast
<b>Service life</b>	≥110000 CY	
<b>Fuel reserves</b>	5% B.F - 100 nm Alternate	
<b>Holding</b>	30 min @ 457 m	30 min @ 1500 ft
<b>A/C configuration</b>	High-wing (wing-mounted engines), Low wing (rear mounted engines)	
<b>nEngine</b>		2 - TurboProp
<b>Design objective</b>		Minimum D.O.C.
<b>External Noise</b>		CHAP14 – 15 epndb

**Table II: Aircraft main geometrical characteristics, Wing engine Mounted configuration WM.**

<b>COVENTIONAL</b>	<b>Regional TurboProp</b>	<b>Reference Aircraft</b>
Wing		Metric
<b>AR</b>		12
<b>S<sub>w</sub></b>		78 m <sup>2</sup>
<b>b<sub>w</sub></b>		30.6 m
<b>c<sub>r</sub></b>		3.33 m
<b>c<sub>r</sub></b>		3.22 m
<b>c<sub>r</sub></b>		1.16 m
<b>mac</b>		2.74 m
Fuselage		
<b>L<sub>f</sub></b>		29,29 m
<b>d<sub>f</sub></b>		3.53 m
Vertical Tail		
<b>S<sub>v</sub></b>		18 m <sup>2</sup>
<b>b<sub>v</sub></b>		5.38 m
Horizontal Tail		
<b>S<sub>h</sub></b>		14.72 m <sup>2</sup>
<b>b<sub>h</sub></b>		8.18 m

TLAR have been used to initialize aircraft configurations, through typical preliminary design sizing, based on statistical approaches. The three views sketch of WM configuration are shown in Fig. 2 and main geometrical characteristics and the aircraft mass breakdown are summarized in Table II and Table III respectively. The baseline configuration consists of a high-wing, T-tail, five abreast fuselage configuration, equipped with two turboprop engines. Reference wing has AR=12, and a fixed fuselage layout with a length of about 30 meters.

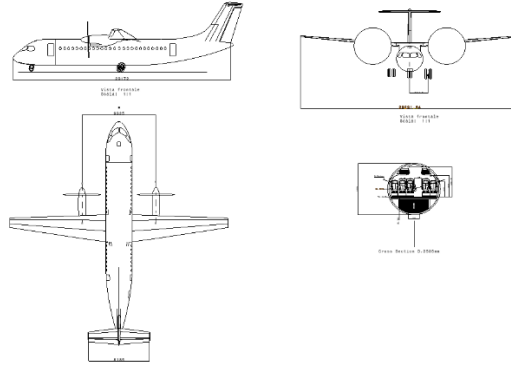

**Fig. 2 Aircraft 3-view, Wing engine Mounted configuration WM, sketch provided by LEONARDO.**

**Table III: Aircraft mass breakdown, Wing engine Mounted configuration WM.**

COVENTIONAL Regional TurboProp Reference Aircraft	
Weights	Metric
<b>MTOW</b>	35380 kg
<b>MZFW</b>	33020 kg
<b>MOEW</b>	21430 kg
<b>M<sub>payload</sub></b>	11590 kg
<b>MLW</b>	34319 kg
<b>M<sub>F</sub>*</b>	2360 kg

\*Based on SFC = 0.36 lb/hph

#### IV. MDAO Workflow

Multidisciplinary design analysis and optimization workflow has been set-up by looking to the available competences within AGILE consortium and needed analysis tools for the task objectives. The workflow has been discussed and agreed among partners during AGILE project meeting, and the final formalized schema is shown in Fig. 3. The workflow consists of a collaborative chain performed from 10 different partners worldwide distributed. All the analysis process and connection are automatically executed, and all the specialists' disciplines are locally executed through BRICS call into RCE environment [11][12].

The overall workflow can be ideally divided into two main process: the “converged MDA” and the “converged DOE” as shown in Fig. 3 in red box and purple box respectively. The converged MDA consists in a multidisciplinary analysis in which few “disciplines” are more time executed within a loop to reach a convergence on a datum variable. The converged DOE is a design of experiments where the abovementioned converged MDA is executed more time by varying design parameters (for instance a geometrical data), in order to obtain response surface (RS) suitable for optimization purposes.

The main workflow steps can be summarized as follows:

- 1) Aircraft initialization: the starting point is the initialized aircraft, as described in Sec. III. The CPACS baseline file describes the initial condition of the aircraft (black box in Fig. 3).
- 2) Engine deck provider: the baseline engine deck is provided and correctly integrated into the baseline file (see red box in Fig. 3), according to the engine top level requirements.
- 3) Aerodynamic competences branches: the overall aerodynamic database is performed a different level of fidelity. The results are updated into the CPACS file of the aircraft and passed to following competences (see red dashed box in Fig. 3).
- 4) Aerostructural sizing, weight competence: here the aircraft structural sizing is performed according the certification load cases. The aircraft empty weight is updated, and results passed to the following tools. Different levels of fidelity are provided as shown in the dashed blue box.
- 5) On-board-system design: here OBS are designed and systems masses updated. Results are passed to the following tools and to Engine Design to account for power-off-takes.
- 6) Performance and mission analysis: overall aircraft performance are computed; mission profile is simulated and block fuel is updated.

- 7) Mass update and rubber engine tools: aircraft mass breakdown is updated according steps (4-5-6); engine deck is scaled according to aircraft MTOW.
- 8) Repeat steps 4 to 7 until Maximum takeoff weight MTOW has reached the convergence.
- 9) Stability and Control calculation.
- 10) Costs & Emission Calculation.
- 11) Availability for Noise calculation and flight simulation.

The described workflow has been assembled in KE-Chain by the using of the real input and output partners' tools files and choosing among different MDAO architectures like *converged* MDA, *converged* DOE or MDO. In Fig. 4 the *converged* DOE strategy is shown. In particular, the yellow boxes represent the pre-coupling functions, the red ones the coupled functions that give a converged value of a certain variable as output, the blue ones the post-coupling functions which give the variables (design, constraint or objective variables) chosen by the integrator as output.

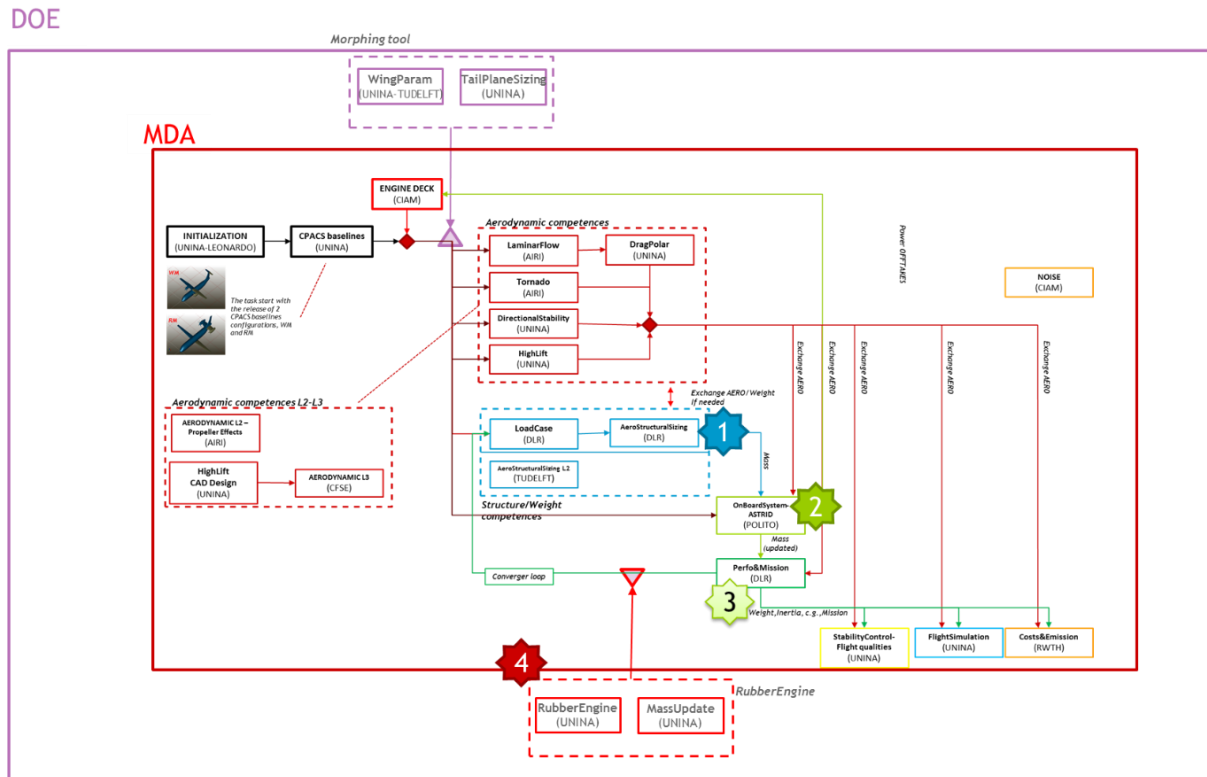

**Fig. 3 MDAO workflow sketch.**

Following the abovementioned workflow steps, and considering that the engine deck is already stored in the baseline file, the yellow boxes cover the steps from 1) to 3) since the first tool is the morphing tool which is used to vary specific design parameters and the others pre-coupling tools are used to compute aerodynamic calculations; the green boxes cover steps from 4) to 8) in a converged loop aiming to provide a converged MTOW value; the red boxes cover steps from 9) to 11) using the converged loop output as input and evaluating the objective functions and the variables that the integrator wants to check at the end of the entire workflow.

The representation shown in Fig. 4 obtained through KE-chain is helpful to check all the connections between tools rapidly and to notice unexpected input, output or connections. In this way it is possible to save time for the debugging phase.

### A. Engine competence

The engine design has been accomplished by CIAM partners, based on LEONARDO specifications. Moreover a “rubber” engine tool has been provided by UNINA to resize engine during convergence loops accordingly aircraft

weight variations. The scaling factors have been provided by CIAM engine designer, as shown in Table IV. As it is possible to notice, the fuel flow and the installed thrust can be linearly scaled with the scale factor (SF), while geometrical dimensions and engine dry mass vary with the square root of the scaling factor. As provided by the engine manufacturer, the proposed scaling factor leads to an inaccuracy lower than 1.5% until a maximum engine scaling of 20%. The expected engine scale is around 5%.

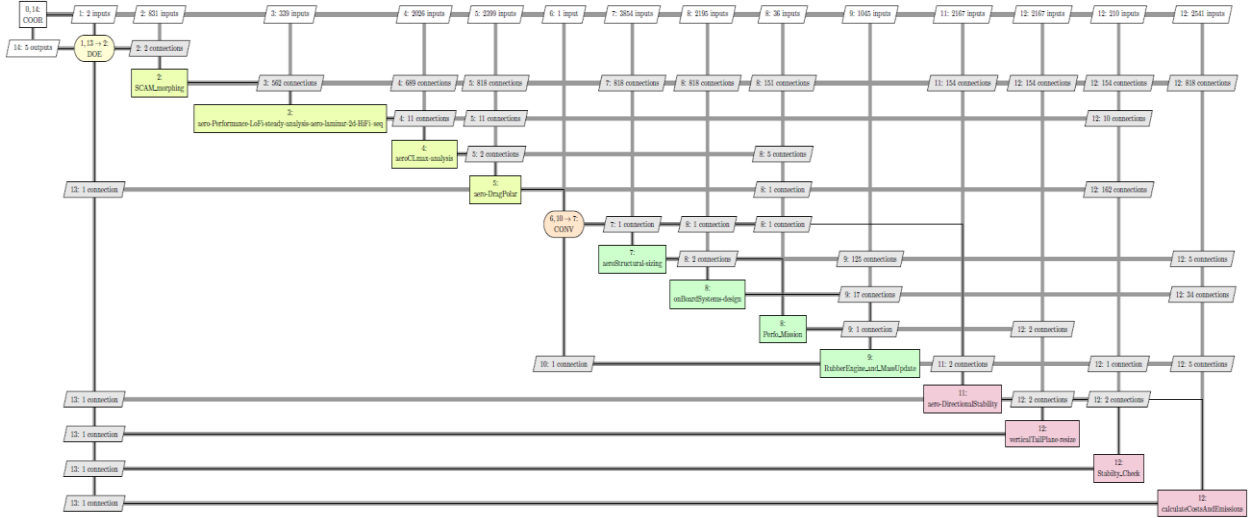

**Fig. 4: Converged DOE workflow assembled in KE-Chain software.**

**Table IV: Engine deck scaling factors provided by CIAM.**

Item	Description	Unit	Scaling
mDotFuel	Fuel flow rate WF	kg/s	SF
shP	Shaft Power SHP	W	SF
thrust	Installed engine net thrust FN	N	SF
thrustUninstalled	Uninstalled engine rig test net thrust FNrig	N	SF
eiNOx	Engine NOx emission index EINOx	kg/kg fuel	1
tSFC	Installed Thrust Specific Fuel Consumption TSFCin	kg/(N*s)	1
mDotAirFlow	Engine Inlet Air Flow WENG	kg/s	SF
engOL	Engine Overall Length EOL	m	SF <sup>0.5</sup>
dEngMax	Max engine outer diameter Deng max	m	SF <sup>0.5</sup>
engDryMass	Engine Dry Mass EDM	kg	SF <sup>0.5</sup>

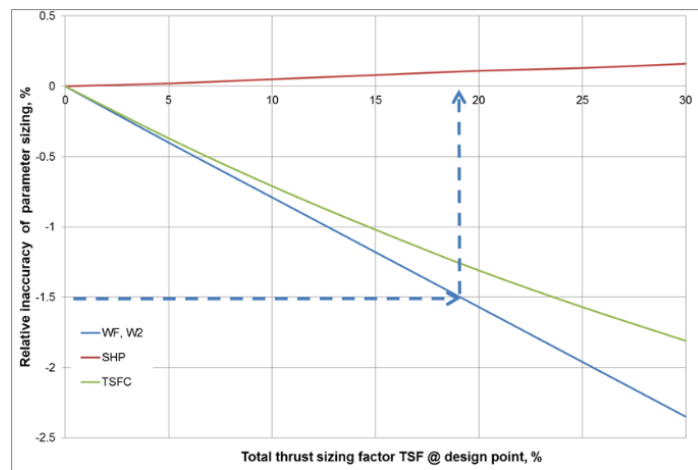

**Fig. 5: Relative inaccuracy of scaled engine parameters vs percentage of engine scale factor.**

In the following paragraphs, the main competences and tool provided by the partners are described.

## B. Aerodynamic competence

The aerodynamic competence is divided into low-fidelity (LoFi) analysis, and high-fidelity analysis (HiFi), performed by UNINA and AIRINNOVA partners.

### 1. AIRINNOVA tools

AIRINNOVA provides a multi-fidelity and multi-method combined aerodynamic analysis for the both WM and RM configurations. The tools are integrated into the MDAO process to provide different “services” according to the tools' fidelity level and the overall design architecture.

The provided services are: *i)* LoFi aerodynamic analysis, *ii)* Laminar flow airfoil analysis, *iii)* HiFi aerodynamic analysis.

The LoFi aerodynamic, inviscid analysis, are performed with Tornado, a VLM (Vortex-Lattice Method) implementation for assessing aero forces and moments on rigid lifting surfaces. Tornado [28], originally written in MATLAB, computes the aerodynamic coefficients and their first order derivatives for lifting surfaces at low speeds. The lifting surfaces are modeled as cambered lamina. The horseshoe vortices can be defined with seven segments to model the geometry of trailing edge movable surfaces. Leading edge movable surfaces can be similarly modeled, but seldom are, since such devices are for high-lift, high-alpha, augmentation, which VLM cannot reliably predict. Effects of compressibility at high low speed Mach numbers ( $<0.75$ ) are included through the Prandtl–Glauert correction [29]. Tornado can import/export CPACS files via a separate wrapper also written in MATLAB. The wrapper reads the geometric information, as well as the paneling and flight conditions from CPACS, translates them into the Tornado native data structures and writes the computed results back to CPACS.

To take into account for airfoil laminar flow, the MSES code has been used [31]. MSES is a viscous-inviscid interaction code that adapts the Euler equations coupled with the boundary layer code including the  $e^N$  method for transition prediction. The 2D laminar flow analysis service by MSES can import/export CPACS file via a MATLAB wrapper. It reads the main wing profiles information, as well as the chord length for each section and the flight conditions from CPACS to calculate the local Reynolds numbers, analyzes each airfoil by setting up the corresponding Mach number and Reynolds number. It will output the upper and lower surfaces transition point for each flight condition, as well as the airfoils aerodynamic coefficients and stall information (angle of attack at zero-lift, maximum lift coefficient, stall angle of attack etc.) as function of the angle of attack.

Finally, the third service provided is HiFi aerodynamic analysis. The used software is SU2 [32] software suite from Stanford University is an open-source, integrated analysis and design tool for complex, multi-disciplinary problems on unstructured computational grids. SU2 is in continued development. Most examples pertain to inviscid flow, but also, RANS flow models with the Spalart–Allmaras and the Menter’s Shear Stress Transport (SST) $k - \omega$  turbulence models can be treated. To analysis the laminar flow and transition phenomena of the wing, the steady, compressible RANS equations Spalart–Allmaras (S-A) turbulence model with Bas-Ckmakcioglu (B-C) transition model is implemented. Moreover, propeller effects can be computed adding actuator disk in the simulation (see Fig. 6).

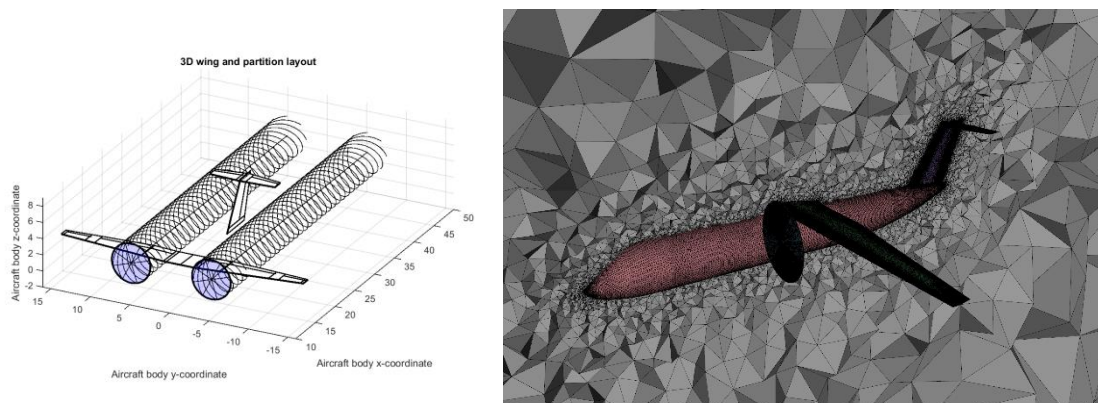

**Fig. 6 Aerodynamic competence, LoFi(left) and HiFi mesh with disk actuator(right).**



## 2. UNINA tools

UNINA provides several tools that cover different area such as *i*) low speed aerodynamic tools which evaluate  $C_{L_{max}}$  in clean, take-off and landing condition;  $C_{D_{flap}}$  used to take into account the drag increment in take-off and landing condition;  $C_{M_{flap}}$  to take into account the flap contribution on the aircraft longitudinal stability; these tools have already been applied on a turboprop aircraft optimization process [8][18] and on the development of an improved high lift prediction method [30]; *ii*) complete aircraft drag polar estimation taking into account the friction drag contribution not estimated by LoFi AIRINNOVA tools.

## C. Structure competence

The aircraft structure design and analysis competence is also divided into LoFi and HiFi analysis, performed respectively by DLR and TuDelft partners.

The aerostructural remote service is provided by DLR Institute of System Architectures in Aeronautics. The service is composed by several physics based disciplinary analysis and design modules, suitable for the preliminary development of the airframe structures [33]. The main components included in the remote service are:

[LCGplus] loads cases generation module, generating the loads envelope and the critical cases the airframe needs to satisfy in order to be sized according to certifications requirements. Critical loads cases include positive and negative maneuvers at several critical velocities (e.g. dive, stall), and including moveables extension and deflections (flaps, ailerons). For the TP design case, 12 critical loads cases have been selected for the sizing of the primary airframes' structures.

[pAir] in-house developed aerodynamics solver for loads analysis. The module performs a pre-processing of the CPACS aircraft geometry, and the generation of aerodynamics panel models (2D or 3D), for the aerodynamics analysis of critical sizing loads cases. For the TP design task, a 2D abstraction of the lifting surfaces has been chosen, delivering the force distribution over the multiple wing objects.

[haDes] in-house aeroelastic FEM modeler and FEA solver. The module performs the pre-processing of the aircraft geometry and its structural layout (e.g. spars and ribs), in order to extract and to generate structural FEM representations of the primary aircraft structures (beam and shell based). The module includes a fluid-structure-interactions interface based on a MLS schema, for the mapping of the forces from the aerodynamics computational grid to the FEM grid, and for the inverse mapping of the displacements computed by the FEA analysis to the aerodynamics grid. The module includes also a sizing and optimization routine for the primary structures, according to strength and stability criteria [34][35]. For the TP task, the primary structures modeled are the wing-box relative to all the wings objects (e.g. tailplanes, main wing), only static analysis.

[wiSe] estimation module of the secondary airframe masses. Based on the geometry model an estimation of the masses of several components is performed, such as moveables (flaps, ailerons), engine pylons, landing gear attachments, actuators attachments, other non-primary masses.

All the modules are executed in fully automated way within the remote service and using CPACS as transfer data model (see Fig. 7). The main output of the remote service includes the mass breakdown of the structural components, as well as detailed results from the aerostructural sizing (such as loads, stress distributions, and mass distributions as shown in Fig. 7). Considering wing composite materials, TuDelft structural design tool can be used.

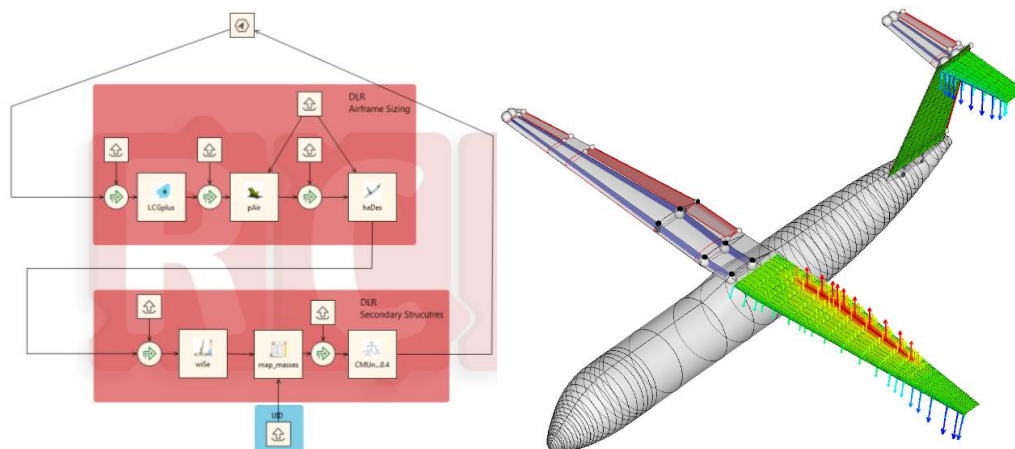

**Fig. 7 DLR Aerostructural sizing remote service, the workflow(left) and a typical flap loads (right).**

#### D. On board systems competence

The on-board systems design and analysis is performed by POLITO partners, based on LEONARDO specifications.

The On-Board Systems (OBS) design is performed by means of ASTRID tool [36]. ASTRID (Aircraft on board Systems sizing and TRade-off analysis in Initial Design) was developed in Politecnico di Torino, it uses semi-empirical and physic-based models. Some of them are dedicated to main equipment design such as actuators for flight control and landing gear movement, avionics, fuel pumps, electric generators and converters, hydraulic pumps and others OBS main components. The other models are more focused on the whole system design in order to include the design of the other equipment such as valves, cables and pipes. Using these models together, it is possible to obtain the design of the power generation and distribution systems that are electric, hydraulic and pneumatic systems and the main user systems such as flight control, avionics, landing gear, fuel, environmental control, ice protection and furnishing (toilet, galley, in-flight entertainment).

ASTRID tool has been used to design the OBS of the WM configuration. Considering previous results [37][38] and the benefits given by the electrification of the OBS [40][41] an All Electric Aircraft (AEA) architecture for OBS has been selected for present aircraft, as prescribed by LEONARDO . As shown in Fig. 8, the hydraulic system and the engine starting system have been completely removed and high voltage electric generation system is selected. The electric generator also provides for engine starting function [42]. All the power demanding systems (i.e. actuators, ice protection and environmental control) are directly supplied by high voltage generation, whereas the other users are supplied using the most common voltage for them. The pneumatic power is produced with dedicated compressors enabling the bleedless technology for the engine.

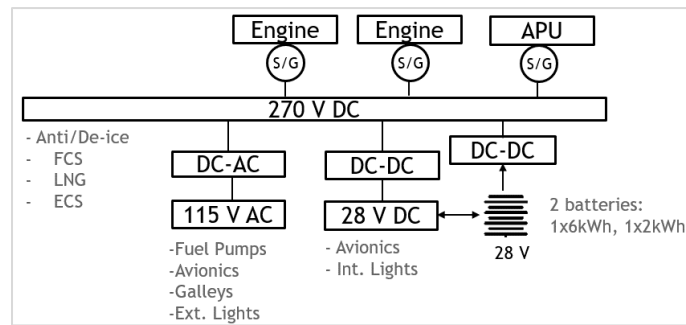

**Fig. 8 OBS architecture selected for both regional TP configurations.**

Considering as inputs the aircraft geometry, the main masses, the mission profile and the OBS architecture selected, ASTRID tool provides the main OBS masses and power off-takes listed in Table V. The main driver is the lower ice protected area of the wing and it is evident only in MCN condition where the ice protection system is considered operating.

**Table V: Example of OBS masses and power off-takes for WM.**

OBS masses (kg)	WM
Systems	2970
Landing gear	1535
Furnishing	3215
OBS power off-takes (kW)	WM
TO APR	45
NTO	23
MCN	190
MCL	85
MCR	85

#### E. Performance competence

Performance calculation has been performed by DLR partners through FSMS tool. Further aircraft performance are computed with UNINA performance tool [26][39], to compute also ground performance.

The DLR's Fast and Simple Mission (FSMS) performance competence evaluates the aircraft performance by simulating the given mission phases. The block fuel consumption for given mission and reserve segments are

calculated. The fast and simple mission simulator is aimed at calculating basic two-dimensional aircraft design missions for initial aircraft design purposes. Aerodynamic, engine, weight and geometrical data are to be provided using the CPACS data exchange format. This aircraft characteristic data can at its turn be generated by other design tools, which can be of any fidelity level. Main results are: information on the aircrafts ability to fly the requested mission, the required fuel and corresponding emissions for this mission, the required runway length for take-off and a scaling factor for engine sizing using a ‘rubber engine’ principle. The Mission simulation outputs mission profiles, mission parameters as shown in Fig. 9. The aircraft is represented by a discrete mass point, flying the predefined two-dimensional mission, based on the standard equations of motion. At every discrete point along the mission, aerodynamic and engine data is obtained by interpolating in the respective performance maps. A standard mission consists of the following components: take-off, climb, cruise to destination airport, descent; and thereafter cruise to alternate airport, descent, loiter at alternative airport, descent and land (see Fig. 9).

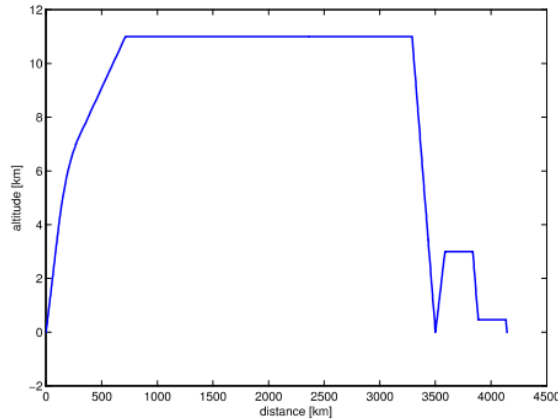

**Fig. 9 Example Mission Profile for AGILE Configuration calculated by Mission Simulation Tool**

#### **F. Stability&Control competence**

In the stability and control competence, provided by UNINA, the overall aerodynamic database is updated considering the fuselage contribution to the complete aircraft longitudinal stability [20], not evaluable through AIRINNOVA tools as shown in the left side of Fig. 6, and the vertical tail contribution to the aircraft directional stability [21]; furthermore, using an additional tool, also the vertical tail is sized considering the minimum control speed evaluation and the yawing moment calculation due to engine thrust in one engine inoperative condition during the take-off phase. Finally, using the updated weight and balance breakdown, a specific tool is used to evaluate stability and control derivatives, neutral point, static margin (SM).

#### **G. Costs&Emission competence**

The cost and emission competence has been evaluated by RWTH partner. The cost and emission analysis tools by the Institute of Aerospace Systems at RWTH Aachen can be used for economic and ecological life cycle assessment of commercial transport aircraft. For the studies carried out within the scope of this paper, the focus is set on the production and operational phase.

**Costs:** RWTH Aachen’s cost module comprises both, non-recurring and recurring costs for an aircraft’s life cycle using low-fidelity methods. For non-recurring costs, the methods include for instance costs for development, testing and test facilities, as well as assembly and transport of materials. Operating costs include indirect (administration, staff, etc.) and direct (charges, fees, maintenance, etc.) operational costs of an airline. The concept and sensitivities of the cost analysis tools are described in two research papers by Franz [44] et al. and Lammering et al. [45].

**Emissions:** The RWTH Aachen emission analysis module calculates aircraft life cycle emissions starting from the development phase to production, operations and finally end-of-life. The implemented methodologies use both semi-empirical as well as physics-based calculations to account for the different emissions throughout the life cycle. Within the module not only the amount of emissions, but also their climate impact considering different climate metrics such as Average Temperature Response (ATR) and Absolute Global Warming Potential (AGWP) are calculated using a climate model, which was first introduced by Dallara [46] in 2010.

**Input/output description of the modules:** Within the scope of the presented use case, the interfaces between the RWTH Aachen modules are twofold. On the one hand, the cost analysis mainly requires information about component

sizes, masses, materials, etc. to calculate the manufacturing costs. For operational costs characteristic values of interest are e.g. flight duration, frequency, and fuel consumption. On the other hand, for the emission assessment, the specified flight mission must be simulated with focus on exhaust emissions and the respective altitudes at which they are emitted. Therefore, the entire performance mission simulation results including a sufficiently detailed engine performance map are taken as an input for the analysis.

### H. Morphing tool competence

The morphing tool competence has been provided by TUDelft University through a tool named sCAM. This one is able to receive as input data some wing geometrical variables, such as  $b_w$ ,  $\Lambda_{LEw}$ ,  $\lambda_w$ ,  $c_{rw}$ ,  $\Gamma_w$ ,  $X_{LEw}$ , and to create a new CPACS baseline file automatically. In this way it is possible to set up a DOE tools chain in which the sCAM tool is the one that provides the new CPACS input file, based on the value of the specific design variables chosen, to all the tools involved in the workflow. Moreover, the UNINA tail planes sizing is used together sCAM to modify horizontal and vertical tails accordingly wing parameters variations.

### I. CAD tool

At the end of the entire workflow the creation of an aircraft CAD model is necessary to carry out and provide HiFi aerodynamic analyses through CFD software. To face this necessity UNINA has provided a CAD maker tool. This one is able to take all the aircraft geometrical data from the baseline file, open a specific CAD software and create a CAD model suited for HiFi analyses automatically. Moreover, the tool is also capable to modify the created model without movables and perform all the operations to create an aircraft CAD model with flaps and slats.

### J. Optimizer

The optimization tools used in the paper is the MOEA Framework\*\*\*\*, which is directly implemented in JPAD library[25][26]. The MOEA Framework is a free and open source Java library for developing and experimenting with multiobjective evolutionary algorithms (MOEAs) and other general-purpose optimization algorithms. Several algorithms are provided out-of-the-box, including genetic algorithms, particle swarm etc. Here the  $\epsilon$ -NSGAI and OMOPSO are used.  $\epsilon$ -NSGA-II is an extension of NSGA-II that uses an  $\epsilon$ -dominance archive and randomized restart to enhance search and find a diverse set of Pareto optimal solutions. Full details of this algorithm are given in Ref. [48]. OMOPSO is a multiobjective particle swarm optimization algorithm that includes an  $\epsilon$ -dominance archive to discover a diverse set of Pareto optimal solutions. OMOPSO was originally introduced in Ref. [49].

The optimization is based on a multi-fidelity response surface, obtained through the above-mentioned DOE. The RS is obtained by running the DOE and interpolated using spline interpolation. Optimization results are described in Sec. V.

## V. Results

The complete workflow developed in KE-Chain has been directly imported into the executable environment RCE, transforming the conceptual schema shown in Fig. 4, in really executable one, as shown in Fig. 10. It is possible to see the complete similarity to the conceptual one, where the red arrow with AGILE logo represents remote services provided by partners. In the present application, only low and medium fidelity analyses have been used for the optimization task. In the following, HiFi analyses will be employed to enrich DOE response surfaces.

The optimization problem is stated as follow (see Eq. 1): the objective function for the innovative turboprop task is the DOC. Together with this, to target CS2 objectives, the architect added a second objective defined as the total global warming potential (GWP), defined accordingly Ruijgrok and Van Paassen [50]. Moreover, the optimization problem constraints, coming from the TLAR shown in Table I and aircraft static margin, imposed by the integrator, have been fixed. The variables for this application are the main wing planform and position parameters, shown in Eq. 1.

---

\*\*\*\* This study used the MOEA Framework, version 2.1, available from <http://www.moeaframework.org/>.

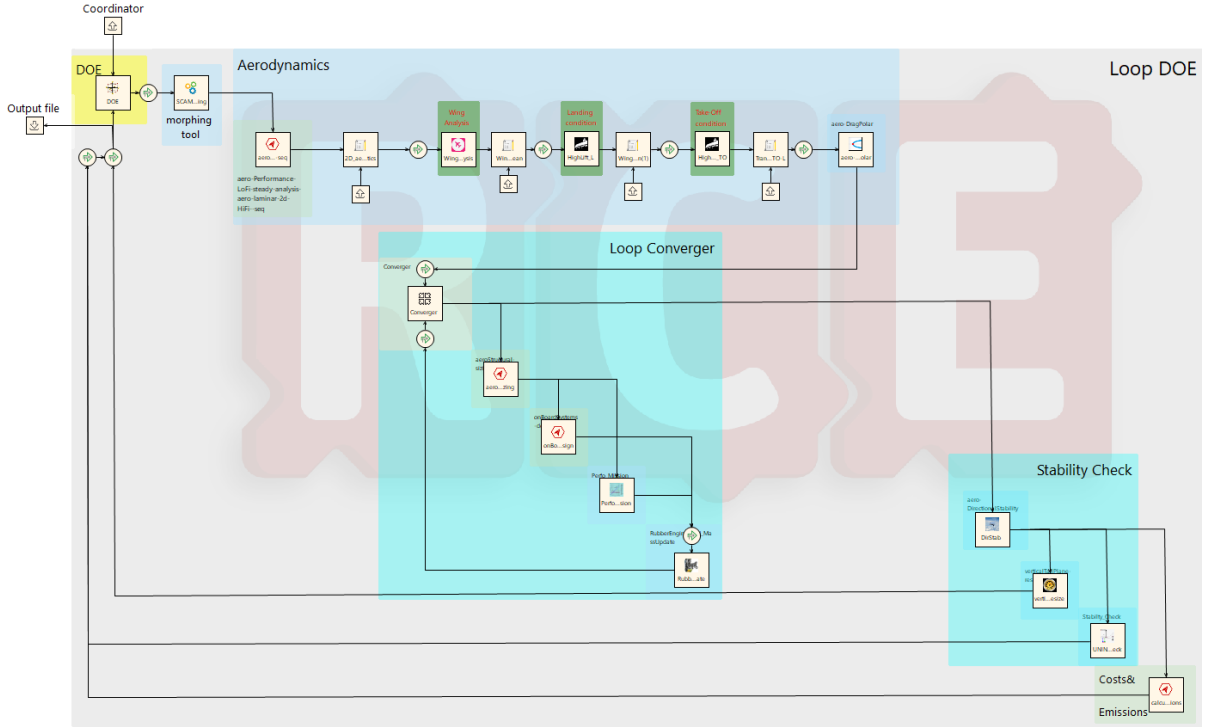

**Fig. 10: Executable workflow in RCE environment automatically obtained from Ke-Chain software.**

Objective functions:

$$\begin{aligned} \text{Min:} \\ f_1 &= DOC \\ f_2 &= GWP \end{aligned}$$

Constraints:

$$\begin{aligned} \text{w. r. t:} \\ SM &\geq 0.05 \text{ (5\%mac)} \\ TOFL &\leq 1500 \text{ m} \\ LNFL &\leq 1500 \text{ m} \\ \text{time to climb} &\leq 13 \text{ min. (from 1500ft to 20000ft)} \end{aligned} \quad (1)$$

Variables:

$$\begin{aligned} \text{by varying:} \\ XLEw \\ ARw \\ \lambda_w \\ b_w \end{aligned}$$

At the end of optimization process both OMOPSO and  $\epsilon$ -NSGAI are converged on similar results in terms of design variables and objective functions as summarized in Table VI. A comparison between the reference aircraft and the optimized one is shown in Fig. 11. It is also possible to notice that in [FIG] the horizontal tail plane is also characterized by different planform in terms of chords and area values. This sizing is performed through a specific tool, provided by UNINA and integrated in RCE environment, capable to size the horizontal tail plane taking into account the variation of the wing position in x direction ( $X_{LEw}$ ).

The objective functions values related to the optimized aircraft are summarized in Table VII. Considering that, for this specific aircraft category, the possible number of flights per day is equal to 6 and it works 358 days per year, assuming 7 days for maintenance check A and B, it is possible to save more than

100 k\$ per year in terms of DOC. Furthermore, it is possible to consider that the GWP reduction means a decrease of more than 300 tons in terms of CO<sub>2</sub> mass emitted.

**Table VI: Wing and horizontal tail plane comparison between reference and optimized aircraft.**

COVENTIONAL Regional TurboProp Aircraft		
	Reference	Optimized aircraft
Wing		Metric
<b>AR</b>	12	9.66
<b>S<sub>w</sub></b>	78 m <sup>2</sup>	75.45 m <sup>2</sup>
<b>b<sub>w</sub></b>	30.6 m	27 m
<b>c<sub>r</sub></b>	3.33 m	3.66 m
<b>c<sub>r</sub></b>	3.22 m	3.54 m
<b>c<sub>r</sub></b>	1.16 m	1.28 m
<b>mac</b>	2.74 m	3.02 m
<b>X<sub>LE</sub></b>	12.8 m	13.03 m
Horizontal		
Tail		
<b>S<sub>h</sub></b>	14.72 m <sup>2</sup>	16 m <sup>2</sup>
<b>b<sub>h</sub></b>	8.18 m	8.53 m

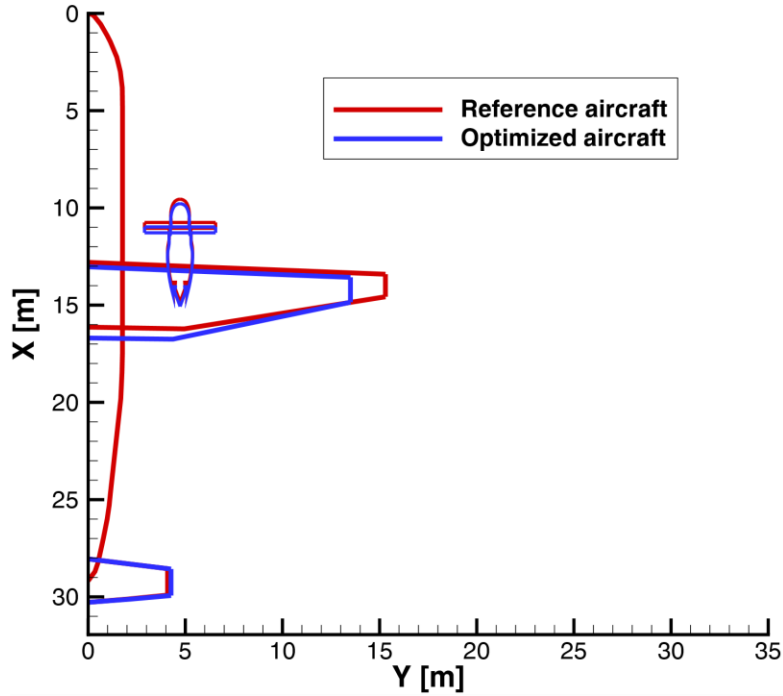

**Fig. 11: Reference and optimized aircraft comparison.**

**Table VII: Objective functions values expressed in percentage of reduction with respect to the values achieved with the reference aircraft configuration.**

COVENTIONAL Regional TurboProp Aircraft			
	Baseline	Optimized	%
<b>DOC (\$/flight)</b>	14949.88	14901.57	
<b>DOC (Millions \$/year)</b>	32.11	32.00	0.3
<b>GWP (kg/flight)</b>	13138.58	12980.96	
<b>GWP (tons/year)</b>	28221.67	27883.12	1.1

## Conclusion

The AGILE paradigm has been stated and applied to the optimization of innovative turboprop configuration showing the potentiality of the developed methodologies. A 40% of time reduction to build-up and run a complete optimization workflow has been experienced. All the AGILE “ingredients” demonstrated a successful approach to speed-up all the phases of typical MDAO process, starting from the conceptual schema creation until an executable one. Moreover, obtained results can be easily monitor and validated during the process by the architect or disciplines specialists. Results shown a DOC reduction of more than 100000 \$ per year and CO<sub>2</sub> decreasing of 320 tons per year.

## Acknowledgments

The research presented in this paper has been performed in the framework of the AGILE project (Aircraft 3<sup>rd</sup> Generation MDO for Innovative Collaboration of Heterogeneous Teams of Experts) and has received funding from the European Union Horizon 2020 Programme (H2020-MG-2014-2015) under grant agreement n° 636202. The authors are grateful to the partners of the AGILE consortium for their contribution and feedback.

## References

- [1] Ciampa, P D; Nagel, B, “The AGILE Paradigm: the next generation of collaborative MDO”, AIAA Aviation 2017, AIAA Paper 2017-4137, Denver, USA, 2017.
- [2] Ciampa, P. D. and Nagel, B., "AGILE Paradigm: developing the next generation collaborative MDO," in 18th AIAA\ISSMO Multidisciplinary Analysis and Optimization Conference, Denver, USA, June 2017.
- [3] Lefebvre, T; Bartoli, N; Lafage, R; Ciampa, P D, “AGILE DC-1 MDO process using an efficient global optimization approach”. 6th EASN Workshop, Porto, Portugal, 2016.
- [4] Della Vecchia, P; Nicolosi, F; De Marco, A; Stingo, L; Nardone, G, “The AGILE method applied to aircraft design at the University of Naples”. 6th EASN Workshop, Porto, Portugal, 2016.
- [5] van Gent, I; Ciampa, P D; Aigner, B; Jepsen, J; La Rocca, G; Schut, J, “Knowledge architecture supporting collaborative MDO in the AGILE Paradigm”, AIAA Aviation 2017, AIAA Paper 2017-4139, Denver, USA, 2017.
- [6] I. van Gent and G. La Rocca and L. Veldhuis, “Composing MDO Symphonies: Graph-based Problem Formulation to Enable Automated Execution for Large MDO Systems”, AIAA Aviation 2017 2017, AIAA Paper 2017-3663, Denver, USA.
- [7] Thierry Lefebvre, Nathalie Bartoli, Sylvain Dubreuil, Marco Panzeri, Riccardo Lombardi, Roberto D'Ippolito, Pierluigi Della Vecchia, Fabrizio Nicolosi, and Pier Davide Ciampa. "Methodological enhancements in MDO process investigated in the AGILE European project", 18th AIAA/ISSMO Multidisciplinary Analysis and Optimization Conference, Denver, Colorado
- [8] Della Vecchia, P., Stingo, L., Corcione, S., Ciliberti, D. Nicolosi, F., De Marco, A. and Nardone, G.: Game theory and evolutionary algorithms applied to MDO in the AGILE European project, 18th AIAA/ISSMO Multidisciplinary Analysis and Optimization Conference. Denver, Colorado.
- [9] I. van Gent, P.D. Ciampa, B. Aigner, J. Jepsen, G. La Rocca, J. Schut, Knowledge architecture supporting collaborative MDO in the AGILE Paradigm, AIAA Paper 2017-4139.
- [10] D. Seider, P. Fischer, M. Litz, A. Schreiber, A. Gerndt, IEEE, “Open source software framework for applications in aeronautics and space”, 2012.
- [11] Ciampa, P D; Moerland, E; Seider, D; Baalbergen, E; Lombardi, R; D'Ippolito, R, “A collaborative Architecture supporting AGILE Design of Complex Aeronautics Products.” AIAA Aviation 2017, AIAA Paper 2017-4138, Denver, USA, 2017.
- [12] Baalbergen, E., Moerland, E., Lammens, W., Ciampa, P. D., “Methods Supporting the efficient Collaborative Design of Future Aircraft”. Paper 844, 6th CEAS Air & Space Conference Aerospace Europe, Bucharest, Romania, 2017.
- [13] Coiro, D.P., Nicolosi, F. “Design of Low-Speed Aircraft by Numerical and Experimental Techniques Developed at DPA,” Aircraft Design Journal, Vol. 4, N. 1, Pag1-18, March 2001. ISSN 1369-8869
- [14] Pascale, L., Nicolosi, F. Design and aerodynamic analysis of a light twin-engine propeller aircraft,(2008) ICAS Secretariat - 26th Congress of International Council of the Aeronautical Sciences 2008, ICAS 2008, 1, pp. 3890-3904.
- [15] Coiro, D.P., Nicolosi, F., Scherillo, F., Maisto, U. "Improving Hang-Glider Maneuverability using multiple winglets: a numerical and experimental investigation", Journal of Aircraft, Vol. 45, N. 3, May-June 2008, pp. 981-989. ISSN 0021-8669. doi: 10.2514/1.33265.
- [16] Coiro, D.P., Nicolosi, F. Grasso, F. "Design and Testing of Multi-Element Airfoil for Short-Takeoff-and-Landing Ultralight Aircraft", Journal of Aircraft, Vol. 46, N. 5, Sept.-Oct. 2009, pp. 1795-1807. ISSN 0021-8669. doi: 10.2514/1.43429.
- [17] Della Vecchia, P., Nicolosi, F. “Aerodynamic guidelines in the design and optimization of new regional turboprop aircraft”, Aerospace Science and Technology (Elsevier) AESCTE Vol. 38, October 2014, pp. 88-104, ISSN 1270-9638, DOI: 10.1016/j.ast.2014.07.018.
- [18] Della Vecchia, P., Stingo, L., Nicolosi, F., De Marco, A., Daniele E. and D’Amato, E, “Application of Game Theory and Evolutionary Algorithm to the Regional Turboprop Aircraft Wing Optimization”, In Evolutionary and Deterministic Methods for Design Optimization and Control With Applications to Industrial and Societal Problems, Springer International Publishing AG, part of Springer Nature, 2019, DOI: [https://doi.org/10.1007/978-3-319-89890-2\\_26](https://doi.org/10.1007/978-3-319-89890-2_26).

- [19] M. Zhang, A. Rizzi, F. Nicolosi, A. De Marco, "Collaborative Aircraft Design Methodology using ADAS linked to CEASIOM", 32<sup>nd</sup> AIAA Applied Aerodynamic Conference Atlanta, GA (USA) , 16-20 June , 2014, doi:10.2514/6.2014-2012.
- [20] Nicolosi, F., Della Vecchia, P., Ciliberti, D., Cusati, V., "Fuselage aerodynamic prediction methods", (2016) Aerospace Science and Technology, 55, pp. 332-343. DOI: 10.1016/j.ast.2016.06.012.
- [21] Ciliberti, D., Della Vecchia, P., Nicolosi, F., De Marco, A., "Aircraft directional stability and vertical tail design: A review of semi-empirical methods", (2017) Progress in Aerospace Sciences, 95, pp. 140-172. DOI: 10.1016/j.paerosci.2017.11.001.
- [22] Nicolosi, F., Corcione, S., Della Vecchia, P., Commuter aircraft aerodynamic characteristics through wind tunnel tests, (2016) Aircraft Engineering and Aerospace Technology, 88 (4), pp. 523-534, DOI: 10.1108/AEAT-01-2015-0008.
- [23] Nicolosi F., De Marco A., Della Vecchia P., Sabetta V. "Roll performance assessment of a light aircraft: flight simulations and flight tests, Aerospace Science and Technology (Elsevier), Volume 76, May 2018, Pages 471-483, , ISSN 1270-9638, <https://doi.org/10.1016/j.ast.2018.01.041>.
- [24] Nicolosi, F., Della Vecchia, P., Corcione, S., "Design and aerodynamic analysis of a twin-engine commuter aircraft" (2015) Aerospace Science and Technology, 40, pp. 1-16. DOI:10.1016/j.ast.2014.07.018.
- [25] Nicolosi, F., De Marco, A., Attanasio, L., Della Vecchia, P. "Development of a Java-based framework for aircraft preliminary design and optimization", (2016) Journal of Aerospace Information Systems, 13 (6), pp. 234-242. DOI: 10.2514/1.1010404.
- [26] Trifari, V., Ruocco, M., Cusati, V., Nicolosi, F., De Marco, A., "Java framework for parametric aircraft design - Ground performance", (2017) Aircraft Engineering and Aerospace Technology, 89 (4), pp. 599-608, DOI: 10.1108/AEAT-11-2016-0209.
- [27] Della Vecchia, P, Malgieri, D., Nicolosi, F., De Marco, A., Numerical analysis of propeller effects on wing aerodynamic: Tip mounted and distributed propulsion, (2018) Transportation Research Procedia, 29, pp. 106-115, doi=10.1016%2fj.trpro.2018.02.010.
- [28] Melin, T. Using Internet Interactions in Developing Vortex Lattice Software for Conceptual Design. Ph.D. Thesis, Department of Aeronautics, Royal Institute of Technology, KTH, Stockholm, Sweden, 2003.
- [29] Anderson, J.D. Modern Compressible Flow with Historical Perspective, 3rd ed.; McGraw-Hill: New York, NY, USA, 2004.
- [30] Della Vecchia, P., Nicolosi, F., Ruocco, M., Stingo, L., De Marco, A., "An improved method for transport aircraft for high lift aerodynamic prediction", 6th CEAS Air & Space Conference Aerospace Europe, Bucharest, Romania, 2017, conference Proceeding ISBN 978-973-0-25597-3
- [31] Drela, M. A User's Guide to MSES 3.05; MIT Department of Aeronautics and Astronautics, July 2007.
- [32] Palacios, F.; Colonno, M.R.; Aranake, A.C.; Campos, A.; Copeland, S.R.; Economon, T.D.; Lonkar, A.K.; Lukaczyk, T.W.; Taylor, T.W.R.; Alonso, J. Stanford University Unstructured (SU2): An open-source integrated computational environment for multi-Physics simulation and design. In Proceedings of the 51st AIAA Aerospace Sciences Meeting including the New Horizons Forum and Aerospace Exposition, Grapevine, TX, USA, 7–10 January 2013; AIAA 2013-0287.
- [33] P. D. Ciampa, T. Zill and B. Nagel, "Aeroelastic Design and Optimization of Unconventional Aircraft Configurations in a Distributed Design Environment," in 53rd AIAA SDM, Honolulu, USA, 2012.
- [34] P. D. Ciampa, T. Zill and B. Nagel, "A Hierarchical Aeroelastic Engine for the Preliminary Design and Optimization of the Flexible Aircraft," in 54th AIAA/ASME/ASCE/AHS/ASC Structures, Structural Dynamics, and Materials Conference, Boston, USA, 2013.
- [35] P. D. Ciampa, T. Zill and B. Nagel, "A Hierarchical Aeroelastic Engine for the Preliminary Design and Optimization of the Flexible Aircraft," in 54th AIAA/ASME/ASCE/AHS/ASC Structures, Structural Dynamics, and Materials Conference, Boston, USA, 2013.
- [36] M. Fioriti, L. Boggero, S. Corpino, A. Isyanov, A. Mirzoyan, R. Lombardi e R. D'Ippolito, "Automated Selection of the Optimal On-board Systems Architecture", in 18th AIAA/ISSMO Multidisciplinary Analysis and Optimization Conference, Denver (CO), 2017.
- [37] P. S. Prakasha, P. D. Ciampa, L. Boggero e M. Fioriti, "Assessment of airframe-subsystems synergy on overall aircraft performance in a Collaborative Design", in 17th AIAA/ISSMO Multidisciplinary Analysis and Optimization Conference, Washington D.C. (USA), 2016.
- [38] P. S. Prakasha, L. Boggero, M. Fioriti, B. Aigner, P. D. Ciampa, K. Anisimov, A. Savelyev, A. Mirzoyan and A. Isyanov, "Collaborative System of Systems Multidisciplinary Design Optimization for Civil Aircraft: AGILE EU project", in 18th AIAA/ISSMO Multidisciplinary Analysis and Optimization Conference, Denver, Colorado (USA), 2017.
- [39] Della Vecchia, P., Corcione, S., Pecora, R., Nicolosi, F., Dimino, I., Concilio, A. Design and integration sensitivity of a morphing trailing edge on a reference airfoil: The effect on high-altitude long-endurance aircraft performance, (2017) Journal of Intelligent Material Systems and Structures, 28 (20), pp. 2933-2946, DOI: 10.1177/1045389X17704521.
- [40] M. J. Cronin, «All-Electric vs Conventional Aircraft: The Production/Operational Aspects,» Journal of Aircraft, vol. 20, n. 6, pp. 481-486, 1983.
- [41] I. Berlowitz, «All/More Electric Aircraft Engine & Airframe Systems Implementation,» in *The 9th Israeli Symposium on Jet Engines and Gas Turbines*, 2010.
- [42] S. Chiesa, S. Farfaglia, M. Fioriti e N. Viola, «Design of all electric secondary power system for future advanced medium altitude long endurance unmanned aerial vehicles,» *Proceedings of the Institution of Mechanical Engineers, Part G: Journal of Aerospace Engineering*, vol. 226, n. 10, pp. 1255-1270, 2012.
- [43] S. Chiesa, S. Corpino, M. Fioriti, A. Rougier e N. Viola, «Zonal safety analysis in aircraft conceptual design: Application to SAve aircraft,» *Proceedings of the Institution of Mechanical Engineers, Part G: Journal of Aerospace Engineering*, vol. 227, n. 4, pp. 714-733 , 2013.



- [44] Franz, K., Lammering, T., Risse, K., Anton, E., and Hoernschemeyer, R., "Economics of Laminar Aircraft Considering Off-Design Performance," 53rd AIAA/ASME/ASCE/AHS/ASC Structures, Structural Dynamics and Materials Conference & 20th AIAA/ASME/AHS Adaptive Structures Conference, American Institute of Aeronautics and Astronautics, Reston, Virginia, 2012.
- [45] Lammering, T., Franz, K., Risse, K., Hoernschemeyer, R., and Stumpf, E., "Aircraft Cost Model for Preliminary Design Synthesis," 50th AIAA Aerospace Sciences Meeting including the New Horizons Forum and Aerospace Exposition, American Institute of Aeronautics and Astronautics, Reston, Virginia, 2012.
- [46] Dallara, E. S., Kroo, I. M., and Waitz, I. A., "Metric for Comparing Lifetime average Climate Impact of Aircraft," AIAA Journal, Vol. 49, No. 8, 2011, pp. 1600–1613.
- [47] Franz, K., Risse, K., and Stumpf, E., "Framework for Sustainability-Driven Aircraft Design," 2013 Aviation Technology, Integration, and Operations Conference, American Institute of Aeronautics and Astronautics, Reston, Virginia, 2013.
- [48] Kollat, J. B., and Reed, P. M. "Comparison of Multi-Objective Evolutionary Algorithms for Long-Term Monitoring Design." *Advances in Water Resources*, 29(6):792-807, 2006.
- [49] Sierra, M. R. and Coello Coello, C. A. "Improving PSO-based multi-objective optimization using crowding, mutation and  $\epsilon$ -dominance." *Evolutionary Multi-Criterion Optimization*, Berlin, Germany, 505-519, 2005.
- [50] Ruijgrok GJJ and Van Paassen DM (2005) *Elements of Aircraft Pollution*. Delft: Delft University Press.