

PROBABILISTIC ASSESSMENT OF HISTORICAL MASONRY WALLS RETROFITTED WITH THROUGH-THE-THICKNESS CONFINEMENT DEVICES

Salvatore Sessa¹, Roberto Serpieri², and Luciano Rosati¹

¹Department of Structures for Engineering and Architecture, University of Naples Federico II
Via Claudio 21, Napoli, Italia
e-mail: {salvatore.sessa2, rosati}@unina.it

² Department of Civil Engineering, University of Sannio
Piazza Roma 21, Benevento, Italia
e-mail: rserpier@unisannio.it

Keywords: Through-the-thickness confinement, Masonry, Shell elements.

Abstract. *A very popular and efficient technique for structural retrofit of historical masonry buildings is represented by Jacketing techniques coupled with Through-the-Thickness (TTJ) ties since the triaxial stress state induced by confinement increases structural ductility and strength. In this respect, the authors have recently developed an Equivalent Single Layer (ESL) First-order Shear Deformation (FSDT) shell theory capable of modeling the TTJ interaction at the global structural level by a computationally less expensive 2D continuum layered formulation.*

The present contribution investigates the sensitivity of the TTJ formulation, used in conjunction with MITC finite elements, with respect to the constitutive uncertainties of an existing masonry panel. To this end, constitutive parameters of the existing structure are characterized by means of random variables which take into account masonry non-homogeneities as well as the state of knowledge of structural parameters. All remaining mechanical and loading parameters are treated herein as deterministic variables and dimensioned according to common design practices of Italian and European code regulations. Therefore, a Monte Carlo simulation is performed in order to get the probability distributions of the structural responses.

A subsequent reliability analysis aims to investigate the influence of TTJ confinement devices on the ultimate limit state of plane elements. Moreover, comparisons are made between the results obtained by the investigated methodology and simpler and more empirical estimates of the strength increment based on the Italian building code recommendations.

1 INTRODUCTION

Through-the-Thickness (TT) confinement has become a popular technique in seismic retrofit of existing masonry structures due to its capability of increasing strength and ductility of structural members [1].

Although confinement is usually taken into account by simplified models adopting suitably defined uniaxial constitutive relationships [2], its effects depend on a complex multi-axial stress state induced in the core of the reinforced elements.

For shear walls, panels and vaults, the traditional uniaxial approach introduces drastic simplifications in the structural analysis. In particular, as shown in [3, 4, 5], one-dimensional finite elements can fail in characterizing the actual behavior of plane elements because they are not capable of accounting for local mechanisms.

In order to perform more accurate nonlinear structural analyses of TT confinement in plane elements, a generalized shell formulation has been recently developed [6]. Based on the Equivalent Single Layer Mindlin First-order Shear Deformation Theory (ESL-FSDT) [7], it assumes a smeared characterization of Through-the-Thickness reinforcements which is capable of estimating the triaxial stress state induced by the confinement effects. This formulation proved to efficiently model stiffness, strength and ductility increments at a global structural level [10], and it has been also implemented in FE code OpenSees [8, 9]. Moreover, numerical applications presented in [6] show how the effects of TT confinements are strongly influenced by the Poisson's ratio of the core material since it rules the mutual interaction between transverse stretching of the core and deformation of the TT links.

This latter issue is pivotal since the knowledge of the constitutive parameters of existing masonry is affected by high uncertainties related to the intrinsic randomness of the material [11]. Hence, influence of the masonry Poisson's ratio should be more properly investigated from a probabilistic point of view.

This contribution presents the results of preliminary probabilistic analyses in which masonry constitutive parameters, namely, strength, stiffness and Poisson's ratio, are defined as random variables, aiming to investigate the influence of transverse confinement on the structural capacity of a masonry wall subject to in-plane loading.

The results herein reported consist in a path-following structural analyses where the horizontal load is monotonically increased until the collapse of the masonry panel. A Monte Carlo Simulation (MCS) has been performed in order to compute the PDFs of the maximum drift and of the maximum horizontal loading as functions of the confinement ratio. Moreover, an Inverse-First-Order Reliability Method (Inverse-FORM) procedure [12] has been performed in order to check the confidence of the MCS results at the attainment of the ultimate limit state conditions provided by the European standards.

2 PROBABILISTIC ANALYSIS

The effects of the confinement are investigated by analyzing the structural response of a rubble-stone masonry wall, shown in Figure 1, subject to in-plane loading with fixed vertical actions and monotonically increasing horizontal load.

In particular, the wall is $4m$ high, $8m$ wide and $0.8m$ thick and it is subject to an uniformly distributed vertical action $Q_v = 400kN$. Transverse links, whose properties are assumed to be deterministic, are modeled by means of a uniaxial, elastic-plastic constitutive model with yield stress $f_{yt} = 450MPa$, Young's modulus $E_t = 200GPa$ and kinematic hardening modulus $H_t = 20GPa$, calibrated on the specifications of the Italian Standards [14].

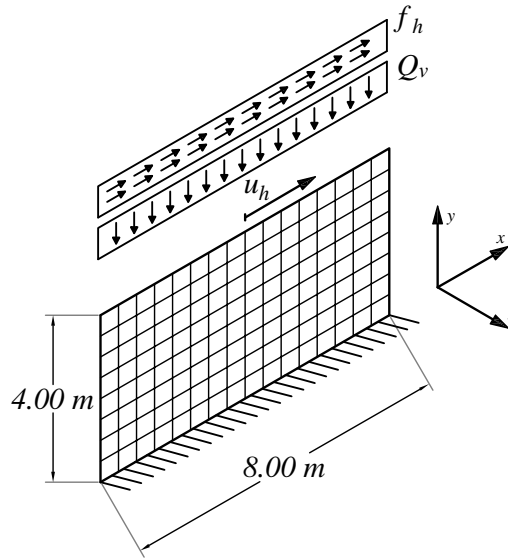

Figure 1: Geometry, constraints and loading scheme of the masonry wall with FE mesh employed in the numerical analyses

Confinement rate $m_t = \Omega_t / \Omega_c$ is defined as the ratio of the TT links cross-sectional area per unit shell midplane area Ω_c . In order to investigate the variability of wall performances with respect to different confinement ratios, the performed analyses assume increasing values of m_t varying between 0 (i.e. unconfined case) and 1%. This ratio is significant if compared with common applications since it approximately corresponds to a regular $0.1 \times 0.1 \text{ m}$ mesh of $\phi 12 \text{ mm}$ TT-links. As a further limit case, $m_t = \infty$ (plane strain) is considered.

A Monte Carlo Simulation (MCS), assuming the masonry constitutive properties as random parameters is therefore performed. It aims to determine the probability distribution of two structural responses in order to characterize the structural performance in terms of strength and ductility. In particular, the analysis evaluates the Cumulative Density Functions (CDFs) of i) the top horizontal drift U_h for a fixed value of the horizontal force f_h and ii) the maximum horizontal reaction F_h induced by a fixed value of the horizontal displacement u_h .

We emphasize that the previous definitions adopt the custom convention of denoting random variables by capital letters, e.g. U_h , and realizations by the corresponding lowercase symbol, e.g., u_h .

Statistics of the adopted random variables are defined in terms of Probability Density Functions (PDFs) summarized in Table 1. In particular, Lognormal distributions are assigned to the Young's modulus and compressive strength, analogously to the concrete statistics suggested in [13].

Concerning the Poisson's ratio, evidences available in the literature are not sufficient for determining a proper probability distribution; nevertheless, theoretical considerations constrain the Poisson's ratio to range within the interval $[0, 0.5]$. For this reason, it is appropriate to adopt a *beta* distribution in order to fulfill its theoretical boundary.

All the considered PDFs are defined in terms of mean and coefficient of variation reported in Table 1. Parameter averages of E and σ_c have been deduced by Italian Standards [16] while coefficients of variations and Poisson's ratio average are sourced from [11, 15]. Finally, all the considered random variables have been assumed to be mutually uncorrelated.

In order to determine the CDFs of the structural responses, threshold values for f_h and u_h have been assumed. In particular, thresholds of f_h are fixed in order to be close to the maximum

resisting shear of the wall while thresholds of u_h have been derived by the conventional Ultimate Limit State (ULS) values provided by the Italian Standards [14].

In particular, denoted as h_m the height of the wall, the u_h thresholds have been set to $0.004h_m$, corresponding to the shear ULS, and $0.006h_m$ corresponding to the bending ULS.

In order to investigate the influence of a two-dimensional analysis on the wall performance, the MCS results are compared with a simplified methodology, suggested by the Italian standards [16], which will be referred to, in short, by the abbreviation SBCA (Strength-Based Confinement Approach). It accounts for the presence of transverse links by multiplying the masonry strength by 1.5.

2.1 Through-the-Thickness Jacketed Shell formulation

Structural response of the confined wall has been computed by the formulation of generalized TTJ ESL-FSDT shell presented in [6] in combination with a 2D layered MITC finite element [7]. In particular, the triaxial stress state of a TT jacketed shell is computed by assuming the core wall to be perfectly confined by uniaxial transverse links. Denoting by t the wall thickness and by z the coordinate along the thickness direction, such an interaction is characterized by compatibility and equilibrium conditions which are added to the governing equations of the shell at each integration point:

$$\int_{-t/2}^{t/2} \varepsilon_z(z) dz = \varepsilon_t \delta_t, \quad \sigma_z(z) + m_t \sigma_t = 0, \quad \forall z \in]-t/2, t/2[, \quad (1)$$

where the pairs $(\varepsilon_z, \varepsilon_t)$ and (σ_z, σ_t) are the normal strain and stress along the z direction in the core and in the TT reinforcement, respectively.

It is worth being emphasized that condition $(1)_1$ is a compatibility statement prescribing that the deformation of the transverse links must be equal to the stretch of the shell core along the TT direction. Conversely, $(1)_2$ is an equilibrium condition stating that, at each abscissa z along the thickness, the uniaxial stress attained by the transverse links must be in equilibrium with the stress component normal to the shell middle plane.

Such a formulation can be used in combination with nonlinear behaviors of the core and the links which have been modeled by means of elastic–plastic constitutive relationships. A Drucker-Prager triaxial yield condition is assumed for the shell core:

$$f = J_2 - \frac{1}{\sqrt{3}} \left(\frac{\sigma_t - \sigma_c}{\sigma_t + \sigma_c} \right) I_1 - \frac{2}{\sqrt{3}} \left(\frac{\sigma_t \sigma_c}{\sigma_t + \sigma_c} \right), \quad (2)$$

where σ_t and σ_c are the tensile and compressive yield values for uniaxial stress, respectively, and I_1 and J_2 the first and second (deviatoric) stress invariants.

Reinforcement bars have been modeled by a tensile–only uniaxial Giuffré-Menegotto-Pinto [8] model with kinematic hardening.

Description	Symbol	Units	Mean μ	c.o.v. δ	Distribution
Shell core Young modulus	E	GPa	1.2	0.22	Lognormal
Shell core Poisson's ratio	ν	–	0.35	0.25	Beta (interval [0, 0.5])
Shell core Drucker-Prager uniaxial tensile strength	σ_t	MPa	0.25	0.19	Lognormal
Shell core Drucker-Prager uniaxial compressive strength	σ_c	MPa	-2.5	0.19	Lognormal

Table 1: Assumed material and geometrical probabilistic parameters for shell core and TT reinforcements.

3 RESULTS AND DISCUSSION

The finite element model has been analyzed by a $2 \cdot 10^5$ -realizations Monte Carlo simulation in order to determine two sets of CDFs. Typical realizations of the load–displacement response, computed for increasing values of the confinement ratio at the random variables averages, are shown in Fig. 2.

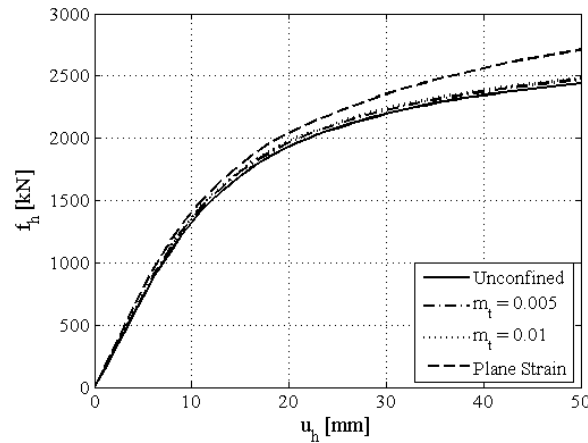

Figure 2: Typical load–displacement responses

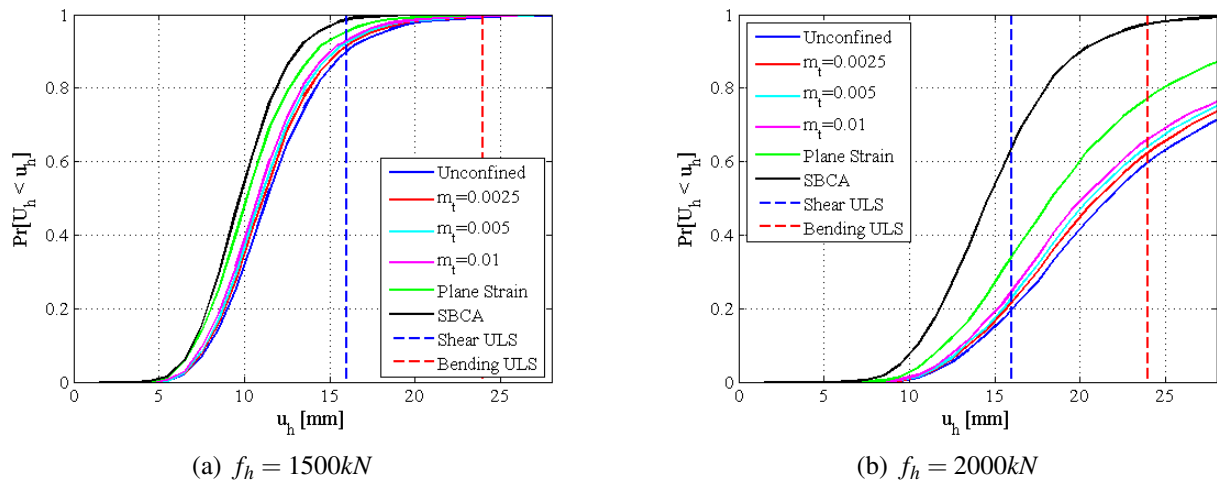

Figure 3: Cumulative probability distributions of the horizontal displacement U_h fixed the seismic demand. Vertical dashed lines represent the assumed displacement thresholds.

A first result, presented in Figures 3(a) and 3(b), has been obtained in terms of CDFs of the horizontal drift U_h computed at the top of the wall for two fixed thresholds of the horizontal load, namely $f_h = 1500\text{ kN}$ and $f_h = 2000\text{ kN}$. The presented curves correspond to increasing values of the transverse confinement ratio, and are bounded by the CDFs corresponding to the unconfined case (blue curves) and to the plane strain case (green curves), respectively. SBCA distributions (black curves) have been computed, accordingly to the Italian Standards, by increasing the masonry strength and assuming a plane stress condition.

A qualitative comparison between Figures 3(a) and 3(b) show how the influence of confinement on the maximum drift distributions turns higher as the horizontal force increases. An

interesting consideration can be made by observing the dashed vertical lines corresponding to the thresholds for which the shear and bending ultimate limit states are attained: as expected, as the confinement increases, the curves attain higher probability values. It is worth being emphasized that the CDFs are defined as $\Pr[U_h \leq u_h]$, i.e. the probability that the horizontal drift U_h turns out to be less than the value u_h . Thus, if the threshold values of u_h correspond to the attainment of the ultimate limit state (dashed curves) the CDFs define the probability that the wall is *safe* if subjected to the considered horizontal force.

SBCA curves attain at higher values of the probability. This shows that such a simplified procedure significantly over-estimates the structural capacity of the wall. In particular, it is worth being emphasized that such a curve provides probability values higher than the plane strain curves which are a theoretical boundary to the confinement effects. In this sense, regardless of the constitutive parameters of the transverse links, confinement cannot be capable of providing the strength estimated by the SBCA.

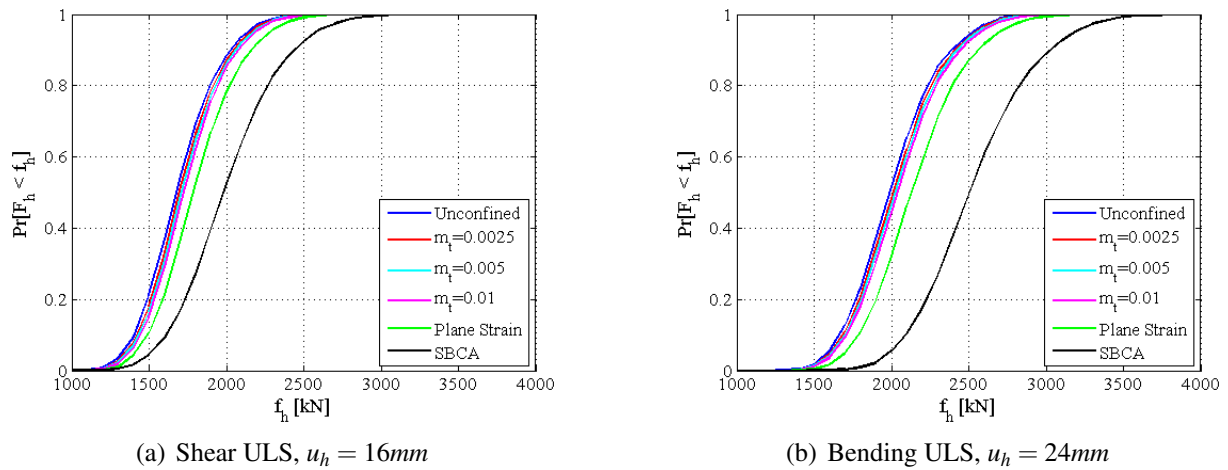

Figure 4: Cumulative probability distribution of the horizontal force F_h computed at the attainment of the ultimate limit states.

Similar conclusions can be deduced by analyzing the curves presented in Figures 4(a) and 4(b) where the CDFs of the horizontal force F_h , computed for the drifts u_h corresponding to the attainment of the shear and bending ULS, are shown.

From a physical point of view, such CDFs characterize the probability that the wall can bear a horizontal reaction when the ULS are attained. In this sense, the CDFs provide the probability of a horizontal strength of the masonry panel.

In general, the strength exhibits increments proportional to the confinement ratio. Moreover, a qualitative comparison of Figures 4(a) and 4(b) shows that the CDFs corresponding to the two ULS displacements are merely translated along the horizontal axis. This circumstance suggests that the strength increment is independent from the ultimate limit state which is adopted for characterizing the wall collapse.

Again, the SBCA curves exhibit a significant drift to the right side of the graph so that the simplified procedure, especially in the case of bending ULS (Fig. 4(a)), significantly over-estimates the wall strength. This is confirmed by the numerical results provided in Table 2 reporting the values of the horizontal force f_h at percentiles $Pr = 5\%$ and $Pr = 10\%$ for each ULS.

The values of F_h presented in Table 2 have been computed by the Inverse-FORM procedure employing the Direct Differentiation Method (DDM) algorithm implemented in OpenSees. In

order to perform the DDM, the implemented formulation has been enriched by the algorithmically-consistent derivatives of the generalized stresses, with respect to the masonry constitutive parameters and to the generalized strains, computed in closed form.

Computations performed by the Inverse-FORM aim to check the accuracy of the Monte Carlo simulation results which is confirmed by a comparison between the numerical values reported in Table 2 and the curves plotted in Figures 4(a) and 4(b).

A numerical comparison between the horizontal force values shows how confinement effects induce a strength increment which is about 3% higher with respect to the unconfined case. Moreover, the strength increment esteemed by the SBCA procedure are significantly higher than the theoretical plane-strain boundary whose strength increment is about 6%.

Links area ratio m_t	Shear ULS, $Pr = 5\%$	Bend. ULS, $Pr = 5\%$	Shear ULS, $Pr = 10\%$	Bend. ULS, $Pr = 10\%$
plane stress	1383.39	1637.86	1468.47	1729.30
$m_t = 0.0025$	1398.41	1663.21	1492.20	1752.95
$m_t = 0.0050$	1412.54	1672.36	1501.81	1761.01
$m_t = 0.0100$	1422.86	1688.37	1510.57	1771.60
plane strain	1463.15	1755.70	1552.04	1850.55
SBCA	1566.33	2039.37	1675.40	2173.94

Table 2: Horizontal force f_h [kN], computed by Inverse-FORM at each ultimate limit state for percentiles $Pr = 5\%$ and $Pr = 10\%$.

A final remark concerns the features of the probability distributions reported in Figures 3 and 4. CDFs of the horizontal drift (Fig. 3) result right-tailed with quite limited asymmetry and kurtosis almost normally-distributed. Distributions of F_h (Fig. 4) present higher asymmetries and kurtosis sensibly far from the normal distribution (see Table 3). In both cases, Gaussians distributions are not suitable for approximating the computed CDFs. This issue suggests that linearization procedures should be carefully adopted in the case of ULS-based reliability analysis and that a proper modeling of transverse confinement, including suitable probability distributions of the random parameters, should be performed.

Links area ratio m_t	$f_h = 1500 \text{ kN}$		$f_h = 2000 \text{ kN}$		$u_h = 16 \text{ mm}$		$u_h = 32 \text{ mm}$	
	γ_1	k	γ_1	k	γ_1	k	γ_1	k
plane stress	0.4710	3.6072	0.5113	3.7580	1.1038	5.3884	-0.1787	1.7563
$m_t = 0.0025$	0.4750	3.6061	0.5073	3.7402	1.0883	5.4444	-0.0895	1.7394
$m_t = 0.0050$	0.4722	3.5950	0.5039	3.7240	1.1063	5.5861	-0.0285	1.7414
$m_t = 0.0100$	0.4673	3.5742	0.5013	3.7036	1.0831	5.5272	0.0266	1.7477
plane strain	0.4731	3.4880	0.5087	3.6485	0.8634	4.4040	0.3031	2.0873

Table 3: Skewness γ_1 and Kurtosis k coefficients of the computed CDFs.

4 CONCLUSIONS

Influence of Through-the-Thickness confinement on the response of a masonry shear wall has been investigated by means of a finite element based probabilistic analysis in which mechanical parameters of the masonry have been modeled as random variables. In particular, the structural performance has been characterized by the probability distributions of the top drift and the maximum horizontal resisting force of a path-following analysis of the masonry panel.

The obtained results have shown that transverse confinement is effective in enhancing the strength and, for a fixed loading demand, it reduces the horizontal bearing. Moreover, the response statistics have shown that probability distributions obtained via Monte Carlo simulation exhibit non-Gaussian trend, thus suggesting that simplified analysis procedures could lead to inaccurate results.

Probability distributions of the structural response obtained by using the TT confined shell element have been compared with the statistics of the corresponding responses obtained by a structural model compliant with the simplified procedure SBCA proposed by the Italian Standards. In particular it has been shown that such an approximate approach can provide unconservative results since it overestimates the resisting force and, at the same time, the horizontal bearing for a given load turns out to be underestimated.

This aspect encourages further investigations concerning the definition of the ultimate limit states for masonry walls and focuses on the confidence of the SBCA, although the definition of the constitutive statistics of the analyzed wall are affected by a limited knowledge of the masonry mechanical properties.

Forthcoming research will be focused on the experimental characterization of the masonry mechanical properties with a special focus on the Young's modulus and Poisson's ratio since experimental campaigns are usually limited to characterize the averages of these material parameters rather than more refined statistical properties. Moreover, a suitable use of the TTJ-Shell in dynamic random vibration procedures [17] will be investigated.

REFERENCES

- [1] M. Corradi, A. Borri, G. Castori, R. Sisti, Shear strengthening of wall panels through jacketing with cement mortar reinforced by GFRP grids. *Composites Part B: Engineering*, **64**, 33–42, 2014.
- [2] J. B. Mander, M.J.N. Priestley, R. Park, Theoretical Stress–Strain Model for Confined Concrete. *Journal of Structural Engineering*, **114**(8), 1804–1826 1988.
- [3] P. Kotronis, F. Ragueneau, J. Mazars, A simplified modelling strategy for R/C walls satisfying PS92 and EC8 design. *Engineering Structures*, **27**(8), 1197–1208 2005.
- [4] N. Valoroso, F. Marmo, S. Sessa, A novel shell element for nonlinear pushover analysis of reinforced concrete shear walls. *Bulletin of Earthquake Engineering*, **13**(8), 2367–2388 2015.
- [5] N. Valoroso, F. Marmo, S. Sessa, Limit state analysis of reinforced shear walls *Engineering Structures*, **61**, 127–139 2014.
- [6] S. Sessa, R. Serpieri, L. Rosati, A continuum theory of through-the-thickness jacketed shells for the elasto-plastic analysis of confined composite structures: Theory and numerical assessment. *Composites Part B: Engineering*, **113**, 225–242 2017.
- [7] E. N. Dvorkin, K. J. Bathe, A continuum mechanics based four-node shell element for general non-linear analysis. *Engineering Computations*, **1**(1), 77–88 1984.
- [8] S. Mazzoni, F. McKenna, M. H. Scott, G. Fenves, *OpenSees command language manual*. Pacific Earthquake Engineering Research (PEER) Center, (2006).
- [9] S. Sessa, R. Serpieri, L. Rosati, Implementation and finite-element analysis of shell elements confined by Through-the-Thickness uniaxial devices. *First European Conference on OpenSees (EOS)*, Porto, Portugal, 19-20 June, 2017.

- [10] S. Sessa, R. Serpieri, L. Rosati, Dynamic FEM analysis of composite shell structures subject to Through-the-Thickness confinement. *3rd International Conference on Mechanics of Composites (MECHCOMP3)*, Bologna, Italy, 4-7 July, 2017.
- [11] L. Schueremans, D. Van Gemert, Probability density functions for masonry material parameters – a way to go ?. *Proc. Structural Analysis of Historical Constructions*, New Delhi, India, 1-8 2006.
- [12] O. D. Ditlevsen, H. O. Madsen, *Structural reliability methods*. J. Wiley & sons, 1996.
- [13] E. E. Melchers, *Structural Reliability, analysis and prediction*. J. Wiley & sons, 2002.
- [14] Min. Infr, Italy, *Nuove Norme Tecniche per le Costruzioni – D.M. 14/01/2008*. 2008.
- [15] G. Mohamad, P. B. Lourenco, H. R. Roman, Mechanics of hollow concrete block masonry prisms under compression: Review and prospects. *Cement and Concrete Composites*, **29**(3), 181–192 2007.
- [16] Min. Infr, Italy, *Circ. 02/02/2009, n. 617 – Istruzioni per l'applicazione delle 'Nuove norme tecniche per le costruzioni' – DM 14/01/2008*. 2009.
- [17] S. Sessa, Multiobjective non-linear random vibration analysis for performance-based earthquake engineering. *Reliability and Optimization of Structural Systems - Proc. 15th IFIP WG 7.5*, Bayern Munich, Germany, April 7-10, 2010.