

Global and local energy minimizers for a nanowire growth model

Irene Fonseca, Nicola Fusco, Giovanni Leoni, and Massimiliano Morini

Abstract. We consider a model for vapor–liquid–solid growth of nanowires proposed in the physical literature. Liquid drops are described as local or global volume-constrained minimizers of the capillarity energy outside a semi-infinite convex obstacle modeling the nanowire. We first address the existence of global minimizers and then, in the case of rotationally symmetric nanowires, we investigate how the presence of a sharp edge affects the shape of local minimizers and the validity of Young's law.

1. Introduction

Nanowires are one-dimensional nanostructures with diameters of the order of nanometers and lengths of microns. In the past decade, there has been a tremendous amount of progress in the technological development of nanowires. Indeed, nanowires are natural candidates in biological applications, nanoelectronic devices, energy-conversion and storage, and mechanical applications (see, e.g., [6, 22]). For example, their narrow diameter allows the penetration of biological structures without damaging them. At the same time, their length makes it possible to transport signals in and out of a cell. Nanowires are also ideal as battery electrodes since their high surface area favors rapid charging.

Because of their importance, understanding nanowire growth and controlling the nanowire dimensions and growth pattern are paramount. The vapor–liquid–solid (VLS) crystal growth method is one of the most common methods for the anisotropic growth of nanowires because of its high flexibility (see [6, 24]). During VLS growth, a nanoscale liquid drop of catalyst (e.g., gold) deposited on a solid plane substrate (e.g., silicon) facilitates the vertical growth of solid nanowires (e.g., gold–silicon alloy) using vapor phase reagents. We refer to [11, 15, 17–20] and the references therein for existing mathematical models of VLS growth.

Following the work of [11, 15, 17, 18] and many others, we consider a continuum framework for nanowire VLS growth.

We model the nanowire as a semi-infinite closed convex cylinder $C \subset \mathbb{R}^2 \times (-\infty, 0]$ and the liquid drop as a set $E \subseteq \mathbb{R}^3 \setminus C$ of finite perimeter. Hence, given $-1 < \lambda < 1$ and

$m > 0$, we define the energy

$$J_{\lambda, \mathbf{C}}(E) := \mathcal{H}^2(\partial^* E \setminus \mathbf{C}) - \lambda \mathcal{H}^2(\partial^* E \cap \mathbf{C}),$$

defined over all sets $E \subset \mathbb{R}^3 \setminus \mathbf{C}$ of finite perimeter such that $|E| = m$. Here, $\partial^* E$ stands for the reduced boundary of E and $|E|$ for the Lebesgue measure of E . The coefficient λ stands for the adhesion coefficient between the drop and the convex set, and $\lambda \mathcal{H}^2(\partial^* E \cap \mathbf{C})$ is the wetting energy (see [13, Chapter 19] and references therein).

The main results of this paper concern the existence of global minimizers and qualitative properties of local minimizers.

We establish global existence under the hypothesis that the convex set \mathbf{C} coincides with a right cylinder of the form $\bar{\omega} \times (-\infty, t_0]$ in the half-space $\mathbb{R}^2 \times (-\infty, t_0]$, for some bounded open convex set $\omega \subset \mathbb{R}^2$ and some $t_0 \leq 0$. This assumption allows us to slide sets E vertically along the lateral boundary of \mathbf{C} without changing the energy $J_{\lambda, \mathbf{C}}(E)$. In Theorem 3.9 we show that for $\lambda = 0$ existence may no longer be true if this property fails.

Our main existence result is Theorem 3.2 below, which establishes that the minimization problem

$$\min\{J_{\lambda, \mathbf{C}}(E) : E \subset \mathbb{R}^3 \setminus \mathbf{C} \text{ of finite perimeter with } |E| = m\}$$

admits a solution. The proof is rather delicate because the sets E lie in the unbounded set $\mathbb{R}^3 \setminus \mathbf{C}$, and thus mass can escape to infinity.

As usual, in variational problems with a volume constraint, to have more flexibility in the choice of competitors E , we replace the volume constraint $|E| = m$ by a volume penalization. To be precise, given $\Lambda > 0$ large, we consider the functional

$$J_{\Lambda, \lambda, \mathbf{C}}(E) := \mathcal{H}^2(\partial^* E \setminus \mathbf{C}) - \lambda \mathcal{H}^2(\partial^* E \cap \mathbf{C}) + \Lambda ||E| - m|, \quad (1)$$

defined over all sets $E \subset \mathbb{R}^3 \setminus \mathbf{C}$ of finite perimeter contained in a ball $B(0, R)$. This problem admits a minimizer $E_{\Lambda, R}$. For such a minimizer we are able to establish density estimates independent of R (and also of \mathbf{C}), which in turn allow us to conclude that each $E_{\Lambda, R}$ is made up of at most κ connected components, with κ independent of R , having equibounded (with respect to R) diameters. Using the sliding property mentioned above we may therefore assume that the minimizers $E_{\Lambda, R}$ are equibounded. Thus, letting $R \rightarrow \infty$, we obtain a minimizer E_{Λ} of the penalized energy (1). Finally, using also a nonvanishing estimate for sets of finite perimeter and finite measure (see Lemma 3.4 below), we show that for Λ sufficiently large, E_{Λ} has volume m , and therefore it is a global minimizer of the original energy $J_{\lambda, \mathbf{C}}$.

Recall that the regularity theory developed in [21] (see also [7]) ensures that if \mathbf{C} is of class $C^{1,1}$ and E is a local minimizer of $J_{\lambda, \mathbf{C}}$ under a volume constraint, then $\partial E \setminus \mathbf{C}$ is a $C^{1,1/2}$ -surface with boundary. Moreover, *Young's law* $\nu_{\mathbf{C}} \cdot \nu_E = \lambda$ holds at all points of the contact line $(\overline{\partial E \setminus \mathbf{C}}) \cap \mathbf{C}$, where ν_E stands for the exterior normal to ∂E . In other words, the surface $\partial E \setminus \mathbf{C}$ meets $\partial \mathbf{C}$ with a contact angle $\theta_{\lambda} = \arccos \lambda$.

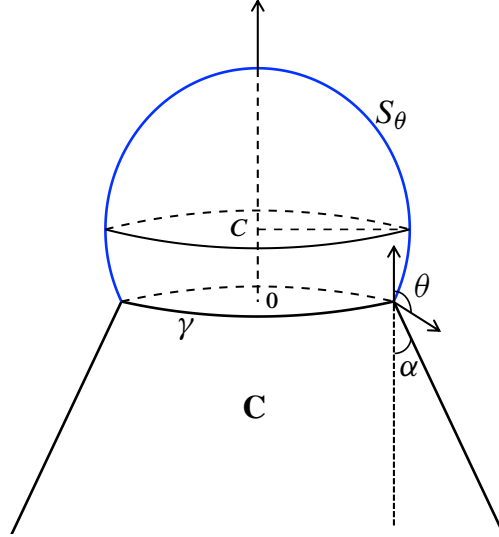

Figure 1. The spherical cap S_θ lying on \mathbf{C} has radius $r = \frac{1}{\sin \theta}$ and center at $C = (0, 0, -\frac{1}{\tan \theta})$.

In the second part of the paper we study qualitative properties of local minimizers. In particular, we investigate how the presence of an edge singularity in \mathbf{C} affects the validity of Young's law. We do so in the simplified case of rotationally symmetric convex sets by considering a semi-infinite truncated cone with circular section of the form

$$\mathbf{C} = \{(x', t) \in \mathbb{R}^2 \times (-\infty, 0] : x' \in (1 - t \tan \alpha) \bar{D}_1\},$$

where D_1 is the open unit ball in \mathbb{R}^2 centered at the origin, and $\alpha \in [0, \frac{\pi}{2})$. We consider spherical caps of the form

$$S_\theta := B\left(\left(0, 0, -\frac{1}{\tan \theta}\right), \frac{1}{\sin \theta}\right) \cap \mathcal{H},$$

where \mathcal{H} is the open half-space

$$\mathcal{H} := \mathbb{R}^2 \times (0, \infty).$$

Note that S_θ meets the plane $\{t = 0\}$ at the angle θ and that $\partial S_\theta \cap \mathbf{C}$ coincides with the top of the truncated cone $D_1 \times \{0\}$; see Figure 1. We recall that S_{θ_λ} is the unique minimizer (up to horizontal translations) of the capillarity problem

$$\min\{\mathcal{H}^2(\partial^* E \setminus \partial \mathcal{H}) - \lambda \mathcal{H}^2(\partial^* E \cap \partial \mathcal{H}) : E \subset \mathcal{H} \text{ of finite perimeter with } |E| = m_\lambda\},$$

where $m_\lambda := |S_{\theta_\lambda}|$ (see [13, Theorem 19.21]). In particular, this implies that a spherical cap ηS_{θ_λ} , lying inside the top of the truncated cone, is a local minimizer for $\eta < 1$ and remains so as $\eta \rightarrow 1^-$. We are now interested in studying the case when the volume m of the drop exceeds m_λ . It is experimentally observed that the presence of a sharp edge has a pinning effect, which inhibits the spreading of the liquid so that the wet part of the drop

remains confined and in fact coincides with the top of nanowire \mathbf{C} for a suitable range of $m > m_\lambda$; see [16]. In the latter regime, the contact angle between the drop and the top of \mathbf{C} is strictly larger than θ_λ and thus Young's law is violated. Finally, for larger values of m the liquid spills over the edge and wets the lateral part of \mathbf{C} .

The main purpose of the second part of the paper is to analytically validate these experimental observations, by proving that if $\theta_\lambda < \theta < \frac{\pi}{2} - \alpha + \theta_\lambda$, then the spherical cap S_θ is a volume-constrained local minimizer of the capillarity energy $J_{\lambda, \mathbf{C}}$. We recall that α is the lateral slope of the truncated cone \mathbf{C} ; see Figure 1.

In order to prove this result, we study the cases $\theta_\lambda < \theta < \frac{\pi}{2}$, $\theta = \frac{\pi}{2} > \theta_\lambda$, and $\max\{\frac{\pi}{2}, \theta_\lambda\} < \theta < \pi$ separately, under the condition $\theta < \frac{\pi}{2} - \alpha + \theta_\lambda$. In the first two cases, we show that S_θ is a strict local minimizer. For a precise formulation we refer to the statements of Theorems 4.5 and 4.10 below. The case $\max\{\frac{\pi}{2}, \theta_\lambda\} < \theta < \pi$ is more delicate, and we are only able to show strict local minimality of S_θ with respect to admissible sets that coincide with S_θ in a neighborhood of the north pole (see Theorem 4.11). The proofs of these theorems rely on calibration techniques and on the construction of foliating families of rotationally symmetric surfaces with constant mean curvature.

Finally, in the range $\theta > \frac{\pi}{2} - \alpha + \theta_\lambda$ we prove that there exist drops arbitrarily close to S_θ spilling over the edge of \mathbf{C} and with strictly lower energy (see Proposition 4.14).

2. Preliminaries

Throughout this paper, given $x \in \mathbb{R}^3$ we write $x = (x', t) \in \mathbb{R}^2 \times \mathbb{R}$. We denote by $B(x, r)$ the open ball in \mathbb{R}^3 centered at x and radius $r > 0$.

In the following, we shall often deal with sets of finite perimeter. We recall that if Ω is an open set, then the perimeter in Ω of a Borel set $E \subset \mathbb{R}^3$ is defined as

$$P(E; \Omega) := \sup \left\{ \int_E \operatorname{div} \xi \, dx : \xi \in C_c^\infty(\Omega; \mathbb{R}^3), \|\xi\|_{L^\infty} \leq 1 \right\}, \quad (2)$$

and that E is said to be a set of *locally finite perimeter* if $P(E; B(0, R)) < \infty$ for all $R > 0$. If $P(E) := P(E; \mathbb{R}^3) < \infty$ we say that E is a set of *finite perimeter*. We recall that if E is a set of locally finite perimeter then the distributional derivative $D\chi_E$ is a Radon measure in \mathbb{R}^3 whose total variation will be denoted by $|D\chi_E|$. For the basic properties of sets of locally finite perimeter we refer to the books [2, 13]. Here we recall that the *reduced boundary* $\partial^* E$ of E is defined as the set of points $x \in \mathbb{R}^3$ such that $|D\chi_E|(B(x, r)) > 0$ for all $r > 0$, the limit

$$\nu_E(x) := - \lim_{r \rightarrow 0^+} \frac{D\chi_E(B(x, r))}{|D\chi_E|(B(x, r))}$$

exists and $|\nu_E(x)| = 1$. Such a vector will be called the *generalized exterior normal* to E at x . Recall also that by De Giorgi's structure theorem (see [13, Chapter 15]), $D\chi_E = -\nu_E \mathcal{H}^2 \llcorner \partial^* E$, and that for every Lipschitz continuous vector field $X: \mathbb{R}^3 \mapsto \mathbb{R}^3$ with

compact support,

$$\int_E \operatorname{div} X \, dx = \int_{\partial^* E} X \cdot \nu_E \, d\mathcal{H}^2.$$

The *essential boundary* $\partial^e E$ is defined as

$$\partial^e E := \mathbb{R}^N \setminus (E^{(0)} \cup E^{(1)}),$$

where $E^{(0)}$ and $E^{(1)}$ are the sets of points where the density of E is 0 and 1, respectively. Since the perimeter measure coincides with the \mathcal{H}^2 measure restricted to the reduced boundary $\partial^* E$, we will sometimes write $\mathcal{H}^2(\partial^* E \cap \Omega)$ instead of $P(E; \Omega)$. In the following, when dealing with a set of locally finite perimeter E , we will always assume that E coincides with a precise representative that satisfies the property $\partial E = \overline{\partial^* E}$; see [13, Remark 16.11]. A possible choice is given by $E^{(1)}$, for which one may check that

$$\partial E^{(1)} = \overline{\partial^* E}. \quad (3)$$

We recall that a sequence $\{F_n\}_n$ of closed sets in \mathbb{R}^3 converges in the *Kuratowski sense* to a closed set F if the following conditions are satisfied:

- (i) if $x_n \in F_n$ for every n , then any limit point of $\{x_n\}_n$ belongs to F ;
- (ii) any $x \in F$ is the limit of a sequence $\{x_n\}_n$ with $x_n \in F_n$.

It is well known that $F_n \rightarrow F$ in the sense of Kuratowski if and only if $\operatorname{dist}(\cdot, F_n) \rightarrow \operatorname{dist}(\cdot, F)$ uniformly on compact sets of \mathbb{R}^3 , with the convention that if $F = \emptyset$, then $\operatorname{dist}(\cdot, F) \equiv +\infty$. In particular, by the Arzelà–Ascoli theorem, any sequence of closed sets admits a subsequence which converges in the sense of Kuratowski.

Remark 2.1 (Kuratowski convergence of convex sets I). Let $\{F_n\}_n$ be a sequence of closed convex sets. Then $F_n \rightarrow F$ in the Kuratowski sense if and only if $\chi_{F_n} \rightarrow \chi_F$ pointwise almost everywhere. Moreover, F is convex.

Indeed, assume first that $F_n \rightarrow F$ in the Kuratowski sense. If $x \notin F$ then $\operatorname{dist}(x, F) > 0$ and thus $\operatorname{dist}(x, F_n) > 0$, that is, $x \notin F_n$, for n large. If F has empty interior, then $|F| = 0$ and thus we have shown the a.e. convergence of the characteristic functions. Otherwise, let $x \in \operatorname{int}(F)$ and let $\delta > 0$ such that $B(x, \delta) \subset F$. We claim that there exists $\delta' \in (0, \delta)$ such that for n large $B(x, \delta') \subset F_n$. Indeed, if not, up to a not relabeled subsequence, there exist $x_n \in \partial F_n$ such that $x_n \rightarrow x$. For every n , let $\nu_n \in \mathbb{S}^2$ be an outer normal direction to ∂F_n at x_n . Without loss of generality we may assume that $\nu_n \rightarrow \nu$ for some $\nu \in \mathbb{S}^2$. Then by Kuratowski convergence $\frac{\delta}{2} = \operatorname{dist}(x_n + \frac{\delta \nu_n}{2}, F_n) \rightarrow \operatorname{dist}(x + \frac{\delta \nu}{2}, F)$, but this is impossible since $\operatorname{dist}(x + \frac{\delta \nu}{2}, F) = 0$. Therefore we have that $\chi_{F_n}(x) \rightarrow \chi_F(x)$ for all $x \in \mathbb{R}^3 \setminus \partial F$ and thus for a.e. x .

The opposite implication then follows by the previous one, recalling that the Kuratowski convergence is compact.

Remark 2.2 (Kuratowski convergence of convex sets II). Let $\{F_n\}_n$ be a sequence of equibounded closed convex sets with nonempty interior, converging in the Kuratowski

sense to a closed convex set F with nonempty interior. Then

$$\mathcal{H}^2 \llcorner \partial F_n \xrightarrow{*} \mathcal{H}^2 \llcorner \partial F \quad \text{weakly* in the sense of measures.} \quad (4)$$

To see this, assume without loss of generality that $0 \in \text{int}(F)$. By Remark 2.1, $\chi_{F_n} \rightarrow \chi_F$ pointwise a.e. and thus for every open set $\Omega \subset \mathbb{R}^3$,

$$\mathcal{H}^2(\partial F \cap \Omega) \leq \liminf_{n \rightarrow \infty} \mathcal{H}^2(\partial F_n \cap \Omega). \quad (5)$$

We now show that

$$\mathcal{H}^2(\partial F_n) \rightarrow \mathcal{H}^2(\partial F). \quad (6)$$

To this aim, we recall that if C_1, C_2 are two bounded convex sets and $C_1 \subset C_2$, then $\mathcal{H}^2(\partial C_1) \leq \mathcal{H}^2(\partial C_2)$. By the Kuratowski convergence of F_n to F , we have that for every $\eta > 1$, $F_n \subset \eta F$ for n large enough and thus $\mathcal{H}^2(\partial F_n) \leq \eta^2 \mathcal{H}^2(\partial F)$. Hence (6) follows, also taking into account (5) applied to $\Omega = \mathbb{R}^3$. In turn, (6), together with (5), implies (4); see for instance [2, Proposition 1.80].

3. Global minimizers

In this section we introduce the capillarity functional and discuss the existence of global minimizers for the corresponding isoperimetric problem. We introduce a class \mathcal{C} of semi-infinite convex cylinders that we will be considering in the sequel.

Definition 3.1. We say that a closed convex set $\mathbf{C} \subset \mathbb{R}^2 \times (-\infty, 0]$ belongs to \mathcal{C} if there exist a bounded open convex set $\omega \subset \mathbb{R}^2$ and $t_0 \leq 0$ such that $\mathbf{C} \cap \{(x', t) : t \leq t_0\} = \bar{\omega} \times (-\infty, t_0]$.

Given $\lambda \in (-1, 1)$ and $\mathbf{C} \in \mathcal{C}$, we consider the *capillarity* functional

$$J_{\lambda, \mathbf{C}}(E) := \mathcal{H}^2(\partial^* E \setminus \mathbf{C}) - \lambda \mathcal{H}^2(\partial^* E \cap \mathbf{C}), \quad (7)$$

defined for all sets $E \subset \mathbb{R}^3 \setminus \mathbf{C}$ of finite perimeter. At times it will be useful to consider the following localized version of the functional $J_{\lambda, \mathbf{C}}$:

$$J_{\lambda, \mathbf{C}}(E; F) := \mathcal{H}^2((\partial^* E \setminus \mathbf{C}) \cap F) - \lambda \mathcal{H}^2(\partial^* E \cap \mathbf{C} \cap F)$$

for all sets of locally finite perimeter E and for all bounded Borel set $F \subset \mathbb{R}^3$.

In this section we establish the existence of global minimizers of $J_{\lambda, \mathbf{C}}$ under a volume constraint.

Theorem 3.2. *Let $\mathbf{C} \in \mathcal{C}$, let $\lambda \in (-1, 1)$ and fix $m > 0$. Then the minimization problem*

$$\min \{ J_{\lambda, \mathbf{C}}(E) : E \subset \mathbb{R}^3 \setminus \mathbf{C} \text{ of finite perimeter with } |E| = m \} \quad (8)$$

admits a solution. Moreover, any minimizer coincides, up to a set of measure zero, with a bounded open set Ω with finitely many connected components. Finally, $\mathcal{H}^2(\partial \Omega' \cap \partial \mathbf{C}) > 0$ for each connected component Ω' of Ω .

We begin with several preliminary results. The first one shows that the functional J is lower semicontinuous.

Lemma 3.3. *Under the assumptions of Theorem 3.2, let $E, E_n, n \in \mathbb{N}$ be sets of finite perimeter contained in $(\mathbb{R}^3 \setminus \mathbf{C}) \cap B(0, R)$ for some ball $B(0, R)$ of radius $R > 0$, and such that $\chi_{E_n} \rightarrow \chi_E$ in $L^1(\mathbb{R}^3 \setminus \mathbf{C})$. Then*

$$\liminf_{n \rightarrow \infty} J_{\lambda, \mathbf{C}}(E_n) \geq J_{\lambda, \mathbf{C}}(E).$$

Proof. The proof of this lemma is that of [13, Proposition 19.3], with an improvement obtained in [23] which allows us to remove the regularity assumption implicitly contained in the hypotheses of that proposition. Set $A := (\mathbb{R}^3 \setminus \mathbf{C}) \cap B(0, R)$. Given $\delta, \varepsilon > 0$, from (2) it is clear we can always find a vector field $\xi_{\varepsilon, \delta} \in C_c^\infty(\mathbb{R}^3; \mathbb{R}^3)$ such that $\|\xi_{\varepsilon, \delta}\|_{L^\infty} \leq 1$, $\text{supp } \xi_{\varepsilon, \delta} \subset A_\delta := \{x \in A : \text{dist}(x, \partial A) < \delta\}$, and

$$\int_{\partial A} \xi_{\varepsilon, \delta} \cdot \nu_A d\mathcal{H}^2 > \mathcal{H}^2(\partial A) - \varepsilon.$$

In turn, this inequality, together with the fact that $\|\xi_{\varepsilon, \delta}\|_{L^\infty} \leq 1$, implies that for every set $F \subset A$ of finite perimeter,

$$\begin{aligned} \int_{\partial A \cap \partial^* F} \xi_{\varepsilon, \delta} \cdot \nu_A d\mathcal{H}^2 &= \int_{\partial A} \xi_{\varepsilon, \delta} \cdot \nu_A d\mathcal{H}^2 - \int_{\partial A \setminus \partial^* F} \xi_{\varepsilon, \delta} \cdot \nu_A d\mathcal{H}^2 \\ &> \mathcal{H}^2(\partial A) - \varepsilon - \mathcal{H}^2(\partial A \setminus \partial^* F) = \mathcal{H}^2(\partial A \cap \partial^* F) - \varepsilon. \end{aligned}$$

Since

$$\int_F \text{div } \xi_{\varepsilon, \delta} dx = \int_{A \cap \partial^* F} \xi_{\varepsilon, \delta} \cdot \nu_F d\mathcal{H}^2 + \int_{\partial A \cap \partial^* F} \xi_{\varepsilon, \delta} \cdot \nu_A d\mathcal{H}^2,$$

we deduce, using the fact that $\text{supp } \xi_{\varepsilon, \delta} \subset A_\delta$,

$$\mathcal{H}^2(\partial A \cap \partial^* F) < \mathcal{H}^2(\partial^* F \cap A_\delta) + \|\text{div } \xi_{\varepsilon, \delta}\|_{L^\infty} |F| + \varepsilon.$$

The rest of the proof goes exactly as in [13, Proposition 19.3], with [13, equation (19.8)] replaced by the inequality above. \blacksquare

In what follows, we will use the following nonvanishing estimate for sets of finite perimeter and finite measure, proven in any dimension in [14].

Lemma 3.4 ([14, Lemma 2.1]). *There exists a constant $C \in (0, \frac{1}{2})$ such that if $E \subset \mathbb{R}^3$ is a set of finite perimeter and finite measure, then, setting $Q := (0, 1)^3$, we have*

$$\sup_{z \in \mathbb{Z}^3} |E \cap (z + Q)| \geq C \min \left\{ \left(\frac{|E|}{\mathcal{H}^2(\partial^* E)} \right)^3, 1 \right\}.$$

We also recall the following well-known property of convex sets; see for instance [9, Lemma 5.1] for a proof.

Lemma 3.5. *Let $\mathbf{C} \in \mathcal{C}$. Then*

$$\mathcal{H}^2(\partial^* F \cap \partial \mathbf{C}) \leq \mathcal{H}^2(\partial^* F \cap (\mathbb{R}^3 \setminus \mathbf{C}))$$

for every bounded set $F \subset \mathbb{R}^3 \setminus \mathbf{C}$ of finite perimeter.

Lemma 3.6. *Let $\mathbf{C} \in \mathcal{C}$ and let $E \subset B(0, R) \setminus \mathbf{C}$ satisfying the following minimality property: there exists $\Lambda \geq 0$ such that*

$$J_{\lambda, \mathbf{C}}(E) \leq J_{\lambda, \mathbf{C}}(F) + \Lambda |F \Delta E| \quad \text{for all } F \subset B(0, R) \setminus \mathbf{C}. \quad (9)$$

Then E is equivalent to an open set Ω such that $\partial \Omega = \partial^e \Omega$, hence $\mathcal{H}^2(\partial \Omega \setminus \partial^* \Omega) = 0$. Moreover, there exist $c_0 = c_0(|\lambda|) > 0$ and $r_0 = r_0(|\lambda|, \Lambda) \in (0, 1)$ (independent of R and \mathbf{C}), such that if $x \in \partial \Omega'$, Ω' being a connected component of Ω , then

$$|\Omega' \cap B(x, r)| \geq c_0 r^3 \quad (10)$$

for every $0 < r \leq r_0$.

Proof. The proof follows the lines of [7, Lemma 2.8]. However, we present it here since some modifications are needed. We start by showing that (10) holds with Ω' replaced by E .

Given $x \in \mathbb{R}^3 \setminus \text{int}(\mathbf{C})$ and $r \in (0, 1)$, we set $m(r) := |E \cap B(x, r)|$. For a.e. such r we have $m'(r) = \mathcal{H}^2(E^{(1)} \cap \partial B(x, r))$ and $\mathcal{H}^2(\partial^* E \cap \partial B(x, r)) = 0$, and we set $F := E \setminus B(x, r)$. Using assumption (9) and simplifying the common contributions of $J_{\lambda, \mathbf{C}}(E)$ and $J_{\lambda, \mathbf{C}}(F)$, we have

$$\begin{aligned} \mathcal{H}^2(\partial^* E \cap (B(x, r) \setminus \mathbf{C})) &\leq \mathcal{H}^2(\partial B(x, r) \cap E^{(1)}) + \Lambda |E \cap B(x, r)| \\ &\quad + |\lambda| \mathcal{H}^2(\partial^* E \cap \partial \mathbf{C} \cap B(x, r)). \end{aligned} \quad (11)$$

By Lemma 3.5,

$$\mathcal{H}^2(\partial^* E \cap \partial \mathbf{C} \cap B(x, r)) \leq \mathcal{H}^2(\partial^*(E \cap B(x, r)) \setminus \mathbf{C}), \quad (12)$$

thus, also using (11), we have

$$\begin{aligned} \mathcal{H}^2(\partial^*(E \cap B(x, r))) &= \mathcal{H}^2(\partial^*(E \cap B(x, r)) \setminus \mathbf{C}) + \mathcal{H}^2(\partial^* E \cap B(x, r) \cap \partial \mathbf{C}) \\ &\leq 2\mathcal{H}^2(\partial^*(E \cap B(x, r)) \setminus \mathbf{C}) \\ &= 2\mathcal{H}^2((\partial^* E \cap B(x, r)) \setminus \mathbf{C}) + 2m'(r) \\ &\leq 4m'(r) + 2\Lambda m(r) + 2|\lambda| \mathcal{H}^2(\partial^* E \cap \partial \mathbf{C} \cap B(x, r)) \\ &\leq 4m'(r) + 2\Lambda m(r) + 2|\lambda| \mathcal{H}^2(\partial^*(E \cap B(x, r)) \setminus \mathbf{C}). \end{aligned} \quad (13)$$

Comparing the first term in the second line with the fourth line of the previous chain of inequalities, we have in particular that

$$\mathcal{H}^2(\partial^*(E \cap B(x, r)) \setminus \mathbf{C}) \leq \frac{1}{1 - |\lambda|} (2m'(r) + \Lambda m(r)).$$

In turn, also using the first inequality in (13) and the isoperimetric inequality, we get

$$\begin{aligned} 3\left(\frac{4\pi}{3}\right)^{\frac{1}{3}}m(r)^{\frac{2}{3}} &\leq \mathcal{H}^2(\partial^*(E \cap B(x, r))) \leq 2\mathcal{H}^2(\partial^*(E \cap B(x, r)) \setminus \mathbf{C}) \\ &\leq \frac{2}{1-|\lambda|}(2m'(r) + \Lambda m(r)) \leq \frac{2}{1-|\lambda|}\left(2m'(r) + \Lambda r\left(\frac{4\pi}{3}\right)^{\frac{1}{3}}m(r)^{\frac{2}{3}}\right) \\ &\leq \frac{4m'(r)}{1-|\lambda|} + \left[3\left(\frac{4\pi}{3}\right)^{\frac{1}{3}} - 1\right]m(r)^{\frac{2}{3}}, \end{aligned}$$

provided $r < r_0$, with r_0 sufficiently small, depending on Λ, λ . Hence, from the previous inequality we get

$$m(r)^{\frac{2}{3}} \leq \frac{4}{1-|\lambda|}m'(r).$$

Observe now that if, in addition, $x \in \partial^*E$, then $m(r) > 0$ for all r as above. Therefore, we may divide the previous inequality by $m(r)^{\frac{2}{3}}$, and integrate the resulting differential inequality in $(0, r)$ to get

$$|E \cap B(x, r)| \geq c_0 r^3 \quad (14)$$

for a suitable positive constant c_0 depending only on $|\lambda|$.

We show that $\overline{\partial^*E} \subset \partial^e E$. To this aim note that (14) holds for every $x \in \overline{\partial^*E}$. Fix $x \in \overline{\partial^*E}$. If $x \in B(0, R) \setminus \mathbf{C}$, denote by $U \subset\subset B(0, R) \setminus \mathbf{C}$ an open neighborhood of x and observe that (9) implies in particular that

$$P(\mathbb{R}^3 \setminus E; U) \leq P(F; U) + \Lambda|(\mathbb{R}^3 \setminus E) \Delta F| \quad \text{for all } F \subset U.$$

Then the same argument as used above, applied to $\mathbb{R}^3 \setminus E$, shows that for r sufficiently small we also have $|B(x, r) \setminus E| \geq c_0 r^3$ (in fact, instead of c_0 we could choose here a constant independent of λ). Thus $x \notin E^{(0)} \cup E^{(1)}$, that is, $x \in \partial^e E$.

On the other hand, if $x \in \partial B(0, R) \setminus \mathbf{C}$, then $|B(x, r) \setminus E| \geq \frac{1}{2}|B(x, r)|$ and again we have that $x \in \partial^e E$. Finally, if $x \in \partial \mathbf{C} \cap \overline{\partial^*E}$ then, since \mathbf{C} is uniformly Lipschitz, there exists a constant $c_2 > 0$ such that for r small, $|\mathbf{C} \cap B(x, r)| \geq c_2 r^3$. This estimate, together with (10), implies that $x \in \partial^e E$. Hence $\mathcal{H}^2(\overline{\partial^*E} \setminus \partial^*E) \leq \mathcal{H}^2(\partial^e E \setminus \partial^*E) = 0$, where the last equality follows from [13, Theorem 16.2].

Now set $\Omega := E^{(1)} \setminus \partial E^{(1)}$. Recalling that $\partial E^{(1)} = \overline{\partial^*E}$ (see (3)), we have that Ω is an open set equivalent to E such $\partial \Omega = \partial E^{(1)}$. Finally, if $x \in \partial \Omega'$, with Ω' a connected component of Ω , we argue exactly as in the proof of (14) using as a competitor $F := (\Omega \setminus \Omega') \cup (\Omega' \setminus B(x, r))$. Indeed, in this case all contributions coming from all connected components but Ω' cancel out, so that (11) reduces to

$$\begin{aligned} \mathcal{H}^2(\Omega' \cap (B(x, r) \setminus \mathbf{C})) &\leq \mathcal{H}^2(\partial B(x, r) \cap \Omega') + \Lambda|\Omega' \cap B(x, r)| \\ &\quad + |\lambda|\mathcal{H}^2(\Omega' \cap \partial \mathbf{C} \cap B(x, r)). \end{aligned}$$

Moreover, (12) still holds with E replaced by Ω' , and the conclusion (10) follows exactly as before. \blacksquare

Remark 3.7. Observe that the proof of Lemma 3.6 also yields the following density estimate. Let $E \subset \mathbb{R}^3$ be a set of locally finite perimeter such that, for any ball B and any set $F \subset \mathbb{R}^N \setminus \mathbf{C}$ with $E \Delta F \subset\subset B$,

$$J_{\lambda, \mathbf{C}}(E; B) \leq J_{\lambda, \mathbf{C}}(F; B) + \Lambda |E \Delta F|. \quad (15)$$

Then E is equivalent to an open set Ω , and (10) still holds with the same constants c_0 and r_0 .

We turn to the proof of Theorem 3.2.

Proof of Theorem 3.2. Since \mathbf{C} and λ will be fixed throughout the proof, we will abbreviate $J_{\lambda, \mathbf{C}}$ as J .

Let $R_0 > 0$ be such that $B(0, R_0) \setminus \mathbf{C}$ contains a ball of volume m . Fix $\Lambda > 0$ (to be determined later) and $R \geq R_0$, and consider the penalized functional

$$J_\Lambda(E) := J(E) + \Lambda ||E| - m|,$$

defined on sets $E \subset \mathbb{R}^3 \setminus \mathbf{C}$ of finite perimeter. We observe that the minimization problem

$$\min\{J_\Lambda(E) : E \subset B(0, R) \setminus \mathbf{C} \text{ is a set of finite perimeter}\} \quad (16)$$

admits a solution. Indeed, let $\{E_n\}_n$ be a minimizing sequence. Then

$$\begin{aligned} J_\Lambda(E_n) &\geq \mathcal{H}^2((\partial^* E_n \cap \overline{B(0, R)}) \setminus \mathbf{C}) \\ &\quad - \mathcal{H}^2(\partial \mathbf{C} \cap B(0, R)). \end{aligned}$$

It follows that $\mathcal{H}^2(\partial^* E_n)$ is equibounded. By a standard compactness argument and by Lemma 3.3, we may extract a subsequence converging in L^1 to a minimizer $E_{\Lambda, R}$ of (16). From the minimality property it follows immediately that

$$J(E_{\Lambda, R}) \leq J(F) + \Lambda |F \Delta E_{\Lambda, R}| \quad \text{for all } F \subset B(0, R) \setminus \mathbf{C}.$$

We apply Lemma 3.6 to deduce that $E_{\Lambda, R}$ is (equivalent to) an open set such that

$$\mathcal{H}^2(\partial E_{\Lambda, R} \setminus \partial^* E_{\Lambda, R}) = 0.$$

Moreover, there exist $c_0 = c_0(\lambda) > 0$ and $r_0 = r_0(\lambda, \Lambda) \in (0, 1)$ (independent of R and \mathbf{C}), such that for every connected component $E_{\Lambda, R}^i$ of $E_{\Lambda, R}$, with $i \in I_{\Lambda, R} \subset \mathbb{N}$, and $x \in \partial E_{\Lambda, R}^i$, we have

$$|E_{\Lambda, R}^i \cap B(x, r)| \geq c_0 r^3 \quad (17)$$

for every $0 < r \leq r_0$. Note that (17) implies that there exists an integer κ , independent of R , such that $\text{card}(I_{\Lambda, R}) \leq \kappa$.

We divide the rest of the proof into several steps.

Step 1. We claim that

$$\sup_{R \geq R_0, \Lambda \geq 1} |E_{\Lambda, R}| < \infty \quad \text{and} \quad \sup_{R \geq R_0, \Lambda \geq 1} \mathcal{H}^2(\partial E_{\Lambda, R}) < \infty. \quad (18)$$

To see this, observe that by the minimality of $E_{\Lambda, R}$,

$$J_{\Lambda}(E_{\Lambda, R}) \leq \mathcal{H}^2(\partial \hat{B}), \quad (19)$$

where \hat{B} is a ball of volume m contained in $B(0, R) \setminus \mathbf{C}$. If $-1 < \lambda < 0$, then

$$\mathcal{H}^2(\partial E_{\Lambda, R} \setminus \mathbf{C}) + |\lambda| \mathcal{H}^2(\partial E_{\Lambda, R} \cap \partial \mathbf{C}) + \Lambda ||E_{\Lambda, R}| - m| = J_{\Lambda}(E_{\Lambda, R}) \leq \mathcal{H}^2(\partial \hat{B}),$$

and the claim follows.

If $0 < \lambda < 1$, then by Lemma 3.5,

$$\lambda \mathcal{H}^2(\partial E_{\Lambda, R} \cap \partial \mathbf{C}) \leq \lambda \mathcal{H}^2(\partial E_{\Lambda, R} \setminus \mathbf{C}). \quad (20)$$

Hence,

$$(1 - \lambda) \mathcal{H}^2(\partial E_{\Lambda, R} \setminus \mathbf{C}) + \Lambda ||E_{\Lambda, R}| - m| \leq J_{\Lambda}(E_{\Lambda, R}) \leq \mathcal{H}^2(\partial \hat{B}),$$

and so

$$\sup_{R \geq R_0, \Lambda \geq 1} |E_{\Lambda, R}| < \infty \quad \text{and} \quad \sup_{R \geq R_0, \Lambda \geq 1} \mathcal{H}^2(\partial E_{\Lambda, R} \setminus \mathbf{C}) < \infty.$$

These inequalities and (20) yield (18).

Step 2. We claim that there exists a constant $d > 0$ (possibly depending on Λ) such that for every $R \geq R_0$, every connected component $E_{\Lambda, R}^i$ of $E_{\Lambda, R}$ satisfies $\text{diam } E_{\Lambda, R}^i \leq d$. Indeed, if not then there exist a sequence $R_n \rightarrow \infty$ and connected components $E_{\Lambda, R_n}^{i_n}$ of E_{Λ, R_n} such that $\text{diam } E_{\Lambda, R_n}^{i_n} \rightarrow \infty$. In turn, for each $n \in \mathbb{N}$ we can find $k_n \in \mathbb{N}$ with $k_n \rightarrow \infty$ and $x_{1,n}, \dots, x_{k_n,n} \in \partial E_{\Lambda, R_n}^{i_n}$ with $|x_{i,n} - x_{j,n}| \geq 1$ for all $i, j \in \{1, \dots, k_n\}$ with $i \neq j$. Hence, by (17) and since the balls $B(x_{i,n}, r_0)$, $i = 1, \dots, k_n$, are mutually disjoint,

$$|E_{\Lambda, R_n}| \geq \sum_{i=1}^{k_n} |E_{\Lambda, R_n}^{i_n} \cap B(x_{i,n}, r_0)| \geq k_n c_0 r_0^3.$$

This implies that $|E_{\Lambda, R_n}| \rightarrow \infty$ as $n \rightarrow \infty$, which contradicts Step 1. Hence the claim holds.

Step 3. We want to show that there exists $M > 0$ (possibly depending on Λ) such that for every $R \geq \max\{R_0, M\}$, up to translating some of the connected components of $E_{\Lambda, R}$, we may construct another minimizer, still denoted by $E_{\Lambda, R}$, contained in $B(0, M)$.

Recall that the number of connected components of $E_{\Lambda, R}$ is at most κ , and that their diameters are bounded by d . It is clear that we can slide vertically along the cylinder all the connected components $E_{\Lambda, R}^i$ that touch $\partial \mathbf{C} \cap (\mathbb{R}^2 \times (-\infty, t_0])$, and move closer to \mathbf{C} the connected components that do not touch \mathbf{C} , in such a way that the new set, still denoted by $E_{\Lambda, R}$, is a minimizer for problem (16) and is contained in a ball of radius M , with M depending only on ω , κ , d , and t_0 .

Step 4. By the previous step and by the second inequality in (18), we can find a sequence $R_n \rightarrow \infty$ and a set E_Λ contained in $B(0, M) \setminus \mathbf{C}$ such that $\chi_{E_{\Lambda, R_n}} \rightarrow \chi_{E_\Lambda}$ in $L^1(\mathbb{R}^3)$. We claim that E_Λ is a global minimizer of the functional J_Λ .

Indeed, let F be a set of finite perimeter contained in $\mathbb{R}^3 \setminus \mathbf{C}$. Assume first that F is bounded. Then there exists n_0 sufficiently large so that $F \subset B(0, R_n)$ for all $n \geq n_0$. By the minimality of E_{Λ, R_n} in $B(0, R_n) \setminus \mathbf{C}$, we have

$$J(E_{\Lambda, R_n}) + \Lambda ||E_{\Lambda, R_n}| - m| = J_\Lambda(E_{\Lambda, R_n}) \leq J_\Lambda(F).$$

By Lemma 3.3, and the fact that $\chi_{E_{\Lambda, R_n}} \rightarrow \chi_{E_\Lambda}$ in $L^1(\mathbb{R}^3)$, letting $n \rightarrow \infty$ in the previous inequality yields $J_\Lambda(E_\Lambda) \leq J_\Lambda(F)$.

On the other hand, if F is unbounded, since

$$\int_0^\infty \mathcal{H}^2(F^{(1)} \cap \partial B(0, r)) dr = |F| < \infty,$$

there exists a sequence $r_n \rightarrow \infty$ such that $\mathcal{H}^2(F^{(1)} \cap \partial B(0, r_n)) \rightarrow 0$ and $\mathcal{H}^2(\partial^* F \cap \partial B(0, r_n)) = 0$. Since $F \cap B(0, r_n)$ is a bounded set of finite perimeter, we have

$$\begin{aligned} J_\Lambda(E_\Lambda) &\leq J_\Lambda(F \cap B(0, r_n)) \\ &= \mathcal{H}^2((B(0, r_n) \cap \partial^* F) \setminus \mathbf{C}) + \mathcal{H}^2((F^{(1)} \cap \partial B(0, r_n)) \setminus \mathbf{C}) \\ &\quad - \lambda \mathcal{H}^2(\partial^* F \cap \partial \mathbf{C} \cap B(0, r_n)) + \Lambda ||F \cap B(0, r_n)| - m| \\ &\leq \mathcal{H}^2(\partial^* F \setminus \mathbf{C}) + \mathcal{H}^2((F^{(1)} \cap \partial B(0, r_n)) \setminus \mathbf{C}) \\ &\quad - \lambda \mathcal{H}^2(\partial^* F \cap \partial \mathbf{C} \cap B(0, r_n)) + \Lambda ||F \cap B(0, r_n)| - m|, \end{aligned}$$

where we used the fact that $\mathcal{H}^2(\partial B(0, r_n) \cap \partial \mathbf{C}) = 0$. Letting $n \rightarrow \infty$, and because $\mathcal{H}^2(F^{(1)} \cap \partial B(0, r_n)) \rightarrow 0$, we obtain that $J_\Lambda(E_\Lambda) \leq J_\Lambda(F)$.

Step 5. We observe that the global minimality of E_Λ implies that

$$J(E_\Lambda) \leq J(F) + \Lambda |F \Delta E_\Lambda| \quad \text{for all } F \subset \mathbb{R}^3 \setminus \mathbf{C}$$

and thus, by the same argument used at the beginning of the proof, E_Λ has finitely many connected components E_Λ^i , $i = 1, \dots, \kappa'$, for some $\kappa' \in \mathbb{N}$. We claim that $\mathcal{H}^2(\partial E_\Lambda^i \cap \partial \mathbf{C}) > 0$ for each $i = 1, \dots, \kappa'$.

Note that $\mathbb{R}^3 \setminus E_\Lambda$ satisfies the following minimality property: for every ball B and every set $F \subset \mathbb{R}^3 \setminus \mathbf{C}$, with $(\mathbb{R}^3 \setminus E_\Lambda) \Delta F \subset B$,

$$J_{-\lambda, \mathbf{C}}(\mathbb{R}^3 \setminus E_\Lambda; B) \leq J_{-\lambda, \mathbf{C}}(F; B) + \Lambda |(\mathbb{R}^3 \setminus E_\Lambda) \Delta F|.$$

In turn, by Remark 3.7, for every $x \in \partial E_\Lambda$ and $r \in (0, r_0)$, we have

$$|B(x, r) \setminus E_\Lambda| \geq c_0 r^3. \quad (21)$$

Assume now by contradiction that $\mathcal{H}^2(\partial E_\Lambda^i \cap \partial \mathbf{C}) = 0$ for some i . Then E_Λ^i minimizes the perimeter among all sets in $\mathbb{R}^3 \setminus \mathbf{C}$ with the same volume, hence it is a ball. We

can now replace E_Λ^i by a ball B tangent to \mathbf{C} at a point x_0 where there exists a unique tangent plane to the cylinder, and disjoint from the other connected components of E_Λ . The resulting set, still denoted by E_Λ , is still a global minimizer of J_Λ . However, (21) is clearly violated at x_0 for r sufficiently small. This contradiction proves the claim.

Step 6. By (19) we have $J_\Lambda(E_\Lambda) \leq \mathcal{H}^2(\partial\hat{B})$, where \hat{B} is any ball in $\mathbb{R}^3 \setminus \mathbf{C}$ with volume m . In particular, this implies that

$$|E_\Lambda| \rightarrow m \quad \text{as } \Lambda \rightarrow \infty. \quad (22)$$

We claim that there exists $\Lambda_0 > 0$ such that for $\Lambda \geq \Lambda_0$, $|E_\Lambda| = m$, and thus E_Λ solves (8). To see this, assume by contradiction that there exists a sequence $\Lambda_n \rightarrow \infty$ such that $|E_{\Lambda_n}| \neq m$. Set $E_n := E_{\Lambda_n}$.

We observe that necessarily $|E_n| < m$, since otherwise we could contradict the minimality by cutting E_n with a plane not intersecting the cylinder. To be precise, given a point x in the projection of E_Λ on $\partial\mathbf{C}$ and a tangent plane Π_x to \mathbf{C} at x , we may cut E_Λ with a suitable plane parallel to Π_x . In this way we strictly lower the energy.

By (18), (22), and Lemma 3.4, there exists a constant $c_2 > 0$ such that $|(z_n + \mathbf{Q}) \cap E_n| \geq c_2 > 0$ for some $z_n \in \mathbb{Z}^3$ and for every n . Note that, up to a subsequence (not relabeled), we may assume that $\chi_{E_n - z_n} \rightarrow \chi_E$ a.e., with E of finite perimeter and $|E| \geq c_2$.

We claim that there exist $\bar{x} \in \partial^* E$ and $\bar{r} > 0$ such that

$$B(\bar{x}, r) \cap (-z_n + \mathbf{C}) = \emptyset \quad \text{for all } n \text{ sufficiently large.} \quad (23)$$

To see this note that, up to a not relabeled subsequence, we may assume that $-z_n + \mathbf{C} \rightarrow \mathbf{C}_\infty$ in the sense of Kuratowski, for a suitable closed convex set \mathbf{C}_∞ .¹ Moreover, by Remark 2.1 we have that $\chi_{-z_n + \mathbf{C}} \rightarrow \chi_{\mathbf{C}_\infty}$ almost everywhere. In particular, this implies that for a.e. $x \in \mathbb{R}^3$, $\chi_E(x)\chi_{\mathbf{C}_\infty}(x) = \lim_n \chi_{E_n - z_n}(x)\chi_{-z_n + \mathbf{C}}(x) = 0$. Hence, $E \subset \mathbb{R}^3 \setminus \mathbf{C}_\infty$. Therefore, there exist $\bar{x} \in \partial^* E \setminus \mathbf{C}_\infty$ and $\bar{r} > 0$ such that $\overline{B(\bar{x}, \bar{r})} \cap \mathbf{C}_\infty = \emptyset$. Recalling that the Kuratowski convergence is equivalent to the locally uniform convergence of the distance functions (see Section 2), (23) immediately follows.

Arguing as in [8, Step 1 of Theorem 1.1], given $\varepsilon > 0$ sufficiently small to be chosen later, we can find a ball $B(x_0, r) \subset B(\bar{x}, \bar{r})$ such that

$$|E \cap B(x_0, r/2)| < \varepsilon r^3, \quad |E \cap B(x_0, r)| > \frac{\pi}{24} r^3.$$

Therefore, for n sufficiently large, we have

$$|E_n \cap B(x_0 + z_n, r/2)| < \varepsilon r^3, \quad |E_n \cap B(x_0 + z_n, r)| > \frac{\pi}{24} r^3.$$

¹Actually it can be easily seen that \mathbf{C}_∞ can only be of one the following three types: the empty set, a translate of \mathbf{C} , a translate of $\bar{\omega} \times \mathbb{R}$. However, this classification is not relevant for the argument of the proof.

We can now continue as in the proof of [8, Theorem 1.1]. For the reader's convenience we recall the main construction. For a sequence $0 < \sigma_n < 1/8$ to be chosen later, we introduce the bi-Lipschitz maps

$$\Phi_n(x) := \begin{cases} (1 - 7\sigma_n)x & \text{if } |x - (x_0 + z_n)| \leq \frac{r}{2}, \\ x + \sigma_n \left(1 - \frac{r^3}{|x - (x_0 + z_n)|^3}\right)x, & \frac{r}{2} \leq |x - (x_0 + z_n)| < r, \\ x & |x - (x_0 + z_n)| \geq r. \end{cases}$$

Setting $\tilde{E}_n := \Phi_n(E_n)$, arguing as in the proof of [8, formula (14)], we have

$$\mathcal{H}^2(\partial E_n \setminus \mathbf{C}) - \mathcal{H}^2(\partial^* \tilde{E}_n \setminus \mathbf{C}) \geq -24\sigma_n \mathcal{H}^2(\partial^* E_n \setminus \mathbf{C}). \quad (24)$$

Moreover, following exactly [8, Step 4 of the proof of Theorem 1.1], we have

$$|\tilde{E}_n| - |E_n| \geq \sigma_n r^3 (c - \varepsilon C)$$

for suitable universal constants $c, C > 0$. If we fix ε so that the negative term inside the parentheses does not exceed half the positive one, we obtain

$$|\tilde{E}_n| - |E_n| \geq \frac{c}{2} \sigma_n r^3. \quad (25)$$

In particular, we can choose σ_n so that $|\tilde{E}_n| = m$. With this choice of σ_n , by (22) $\sigma_n \rightarrow 0$, and it follows from (24) and (25) that

$$J_{\Lambda_n}(\tilde{E}_n) - J_{\Lambda_n}(E_n) \leq 24\sigma_n \mathcal{H}^2(\partial^* E_n \setminus \mathbf{C}) - \Lambda_n \frac{c}{2} \sigma_n r^3 < 0$$

for n large, thus contradicting the minimality of E_n . Therefore, the claim of the step is proven, and the conclusion of the theorem follows. \blacksquare

Remark 3.8. Observe that in the proof of Theorem 3.2 we have shown that every minimizer Ω of problem (8) satisfies (15) (with Ω in place of E) for any ball B and any set $F \subset \mathbb{R}^3 \setminus \mathbf{C}$, with $\Omega \Delta F \subset\subset B$. Therefore, the classical regularity theory for Λ -minimizers of the perimeter (see for instance [13]) implies that $\partial\Omega \setminus \mathbf{C}$ is a smooth surface with constant mean curvature. In turn, concerning the boundary regularity, we may apply [7, Theorem 1.2 and Corollary 1.4] to infer that if $\partial\mathbf{C}$ is of class $C^{1,1}$ in a neighborhood U of a point $x \in \Gamma := \overline{\partial\Omega} \setminus \mathbf{C}$, then in the same neighborhood Γ is a $C^{1,1/2}$ -surface with boundary. Moreover, Young's law $\nu_{\mathbf{C}} \cdot \nu_{\Gamma} = \lambda$ holds on $U \cap \Gamma \cap \mathbf{C}$, where ν_{Γ} denotes the unit normal to Γ pointing outwards with respect to Ω .

Note that in the argument of Theorem 3.2 we used in a crucial way the fact that we can slide sets vertically along the lateral boundary of the obstacle \mathbf{C} without changing the energy. In the next theorem, we show that for $\lambda = 0$ existence may no longer be true if

this property fails. To this end, we consider the following class of semi-infinite truncated cones: we say that $\mathbf{C} \in \tilde{\mathcal{C}}$ if

$$\mathbf{C} = \{(x', t) \in \mathbb{R}^2 \times (-\infty, 0] : x' \in (1 - t \tan \alpha)\bar{\omega}\},$$

where $\omega \subset \mathbb{R}^2$ is a bounded open *strictly convex* set and $\alpha \in (0, \pi/2)$. We denote by $R_{\text{in}}(\omega)$ the inradius of ω , that is, the radius of the largest open disk contained in ω .

Theorem 3.9 (Existence vs nonexistence for $\lambda = 0$). *Let $\mathbf{C} \in \tilde{\mathcal{C}}$, and for $m > 0$ consider the minimization problem*

$$\min\{\mathcal{H}^2(\partial^* E \setminus \mathbf{C}) : E \subset \mathbb{R}^3 \setminus \mathbf{C} \text{ of finite perimeter with } |E| = m\}. \quad (26)$$

Then, setting $m_0 := \frac{2}{3}\pi R_{\text{in}}(\omega)^3$, we have

- (i) if $m \in (0, m_0]$, then problem (26) admits a solution, and all solutions are given by half-balls lying on $\omega \times \{0\}$;
- (ii) if $m > m_0$, then problem (26) has no solution.

Proof. Let $\mathbf{C} \in \tilde{\mathcal{C}}$. By the relative isoperimetric inequality proved in [4], if $E \subset \mathbb{R}^3 \setminus \mathbf{C}$ is a set of finite perimeter and finite mass m , then its perimeter is larger than or equal to half the perimeter of the ball with volume $2m$, that is,

$$\mathcal{H}^2(\partial^* E \cap (\mathbb{R}^3 \setminus \mathbf{C})) \geq 3\left(\frac{2}{3}\pi\right)^{\frac{1}{3}} m^{\frac{2}{3}}.$$

Moreover, equality holds if and only if E is a half-ball supported on a facet of \mathbf{C} ; see [9, Theorem 1.2]. Hence item (i) follows.

Assume now that $m > m_0$. We use a translation argument, and set $\tilde{\mathbf{C}} := \mathbf{C} - \frac{e_3}{\tan \alpha}$. Note that

$$\tilde{\mathbf{C}} = \{(x', t) \in \mathbb{R}^2 \times (-\infty, -1/\tan \alpha] : x' \in -(t \tan \alpha)\bar{\omega}\},$$

and, since $m > m_0$, there is no half-ball of volume m supported on $\tilde{\mathbf{C}}$. Thus, using [9, Theorem 1.2] again, we have

$$\mathcal{H}^2(\partial^* E \cap (\mathbb{R}^3 \setminus \tilde{\mathbf{C}})) > 3\left(\frac{2}{3}\pi\right)^{\frac{1}{3}} m^{\frac{2}{3}} \quad (27)$$

for every $E \subset \mathbb{R}^3 \setminus \tilde{\mathbf{C}}$ with volume m .

Fix $x'_0 \in \partial\omega$ for which there exists a unique tangent line ℓ to ω at x'_0 . Then the plane Π generated by ℓ and by the line $s \mapsto (-(s \tan \alpha)x'_0, s)$, $s \in \mathbb{R}$, is the unique tangent plane to $\tilde{\mathbf{C}}$ at $(-(t \tan \alpha)x'_0, t)$ for all $t < -1/\tan \alpha$. Fix $s_0 < -1/\tan \alpha$, and set $x_n := (-(ns_0 \tan \alpha)x'_0, ns_0)$. Observe that for every $r > 0$, $(-x_n + \tilde{\mathbf{C}}) \cap B(0, r) = n(-x_1 + \tilde{\mathbf{C}}) \cap B(0, r)$, provided that n is large enough. Since Π is the tangent plane to $\tilde{\mathbf{C}}$ at x_1 , we have that $\{n(-x_1 + \tilde{\mathbf{C}})\}$ converges in the Kuratowski sense to the closed half-space Π^- with boundary Π containing $\tilde{\mathbf{C}}$ and, by Remark 2.2,

$$\mathcal{H}^2 \llcorner (-x_n + \partial\tilde{\mathbf{C}}) \xrightarrow{*} \mathcal{H}^2 \llcorner \Pi \quad (28)$$

weakly* in the sense of measures. Denote by r_m the radius of the ball of volume $2m$. The Kuratowski convergence of $(-x_n + \tilde{\mathbf{C}}) \cap \overline{B(0, r_m)}$ to $\Pi^- \cap \overline{B(0, r_m)}$, again by Remark 2.2, implies that

$$\begin{aligned} \mathcal{H}^2(\partial((-x_n + \tilde{\mathbf{C}}) \cap B(0, r_m))) &= \mathcal{H}^2(\partial(\tilde{\mathbf{C}} \cap B(x_n, r_m))) \\ &\rightarrow \mathcal{H}^2(\partial(\Pi^- \cap B(0, r_m))). \end{aligned} \quad (29)$$

Observe also that from (28) and the fact that $(\mathcal{H}^2 \llcorner \Pi)(\partial B(0, r_m)) = 0$, we have that $\mathcal{H}^2(\partial \tilde{\mathbf{C}} \cap B(x_n, r_m)) \rightarrow \mathcal{H}^2(\Pi \cap B(0, r_m))$. From this convergence and (29), we then have

$$\mathcal{H}^2(\partial B(x_n, r_m) \setminus \tilde{\mathbf{C}}) \rightarrow \mathcal{H}^2(\partial B(0, r_m) \setminus \Pi^-) = 3 \left(\frac{2}{3} \pi \right)^{\frac{1}{3}} m^{\frac{2}{3}}. \quad (30)$$

Finally, note that by the convexity of $\tilde{\mathbf{C}}$, $|B(x_n, r_m) \setminus \tilde{\mathbf{C}}| \geq m$. Replacing $B(x_n, r_m) \setminus \tilde{\mathbf{C}}$ with the set E_n obtained by cutting $B(x_n, r_m) \setminus \tilde{\mathbf{C}}$ with a plane parallel to Π in such a way that $|E_n| = m$, we clearly have that $\mathcal{H}^2(\partial E_n \setminus \tilde{\mathbf{C}}) \leq \mathcal{H}^2(\partial B(x_n, r_m) \setminus \tilde{\mathbf{C}})$ and thus, recalling (27), (30),

$$\mathcal{H}^2(\partial E_n \setminus \tilde{\mathbf{C}}) \rightarrow 3 \left(\frac{2}{3} \pi \right)^{\frac{1}{3}} m^{\frac{2}{3}}.$$

We then conclude that $3 \left(\frac{2}{3} \pi \right)^{\frac{1}{3}} m^{\frac{2}{3}}$ coincides with the infimum of problem (26), and that it is not attained. \blacksquare

Remark 3.10. Note that the strict convexity assumption on $\partial\omega$ is necessary for the non-existence part of the previous theorem. Indeed, the reader may check that if $\partial\omega$ contains a line segment then the corresponding truncated cone \mathbf{C} has a flat facet which becomes arbitrarily large at $-\infty$. Hence, for every $m > 0$, it is always possible to find a half-ball of mass m supported on such a facet. Thus, in this case problem (26) always has a solution.

4. The case of nanowires with circular section

Throughout this section, given an open ball $B(x_0, r)$ and a unit vector $\nu \in \mathbb{S}^2$, we write

$$\partial B_\nu^\pm(x_0, r) := \{x \in \partial B(x_0, r) : \pm(x - x_0) \cdot \nu > 0\}. \quad (31)$$

Given $R > 0$ and $\lambda \in (-1, 1)$, note that if $x \in \partial B(-R\lambda e_3, R) \cap \{t = 0\}$, then the outward normal ν to the ball at x satisfies $\nu \cdot e_3 = \lambda$. Define

$$S_{\lambda, R} := B(-R\lambda e_3, R) \cap \mathcal{H}, \quad (32)$$

where

$$\mathcal{H} := \{(x', t) \in \mathbb{R}^3 : t > 0\}.$$

Recall that the spherical caps $S_{\lambda, R}$ are the unique minimizers (up to horizontal translations) of the capillarity problem

$$\min\{\mathcal{H}^2(\partial^* E \setminus \partial \mathcal{H}) - \lambda \mathcal{H}^2(\partial^* E \cap \partial \mathcal{H}) : E \subset \mathcal{H} \text{ of finite perimeter, } |E| = |S_{\lambda, R}|\};$$

see [13, Theorem 19.15].

Given $\alpha \in [0, \frac{\pi}{2})$ and $r > 0$, we set

$$\mathfrak{C} = \{(x', t) \in \mathbb{R}^2 \times (-\infty, 0] : x' \in (1 - t \tan \alpha) \bar{D}_r\}, \quad (33)$$

where D_r denotes the planar disk centered at the origin with radius r . Without loss of generality, we may assume $r = 1$. We study the local minimality of the spherical caps S_θ with contact region coinciding with the top of \mathfrak{C} , that is, with the set

$$\mathfrak{C}_{\text{top}} := \bar{D}_1 \times \{0\},$$

and with contact angle θ . More precisely, for $\theta \in (0, \pi)$, setting $R_\theta := \frac{1}{\sin \theta}$, we define

$$S_\theta := S_{\cos \theta, R_\theta},$$

where we used the notation introduced in (32) (see Figure 1 in the introduction). Recalling that the volume of a spherical cap of radius r and height h is given by $\frac{\pi h^2}{3}(3r - h)$, we get

$$|S_\theta| = \frac{\pi}{3} \frac{(1 - \cos \theta)^2 (2 + \cos \theta)}{\sin^3 \theta}. \quad (34)$$

It can be checked that the function $\theta \rightarrow |S_\theta|$ is strictly increasing in $(0, \pi)$. We denote by γ the contact line, that is, the circle $\partial D_1 \times \{0\}$. We set

$$\theta_\lambda := \arccos \lambda.$$

In this section we address the local and global minimality properties of the spherical caps S_θ . In particular, we identify the condition preventing the occurrence of the spillover on the lateral boundary of \mathfrak{C} .

Since we will work with a fixed convex set of the form (33), we will only highlight the dependence of the functional in (7) on λ and therefore, to simplify the notation, we will write J_λ instead of $J_{\lambda, \mathfrak{C}}$.

As a preliminary result that will be used later, we prove a global minimality property of spherical caps with respect to variations contained in \mathcal{H} .

Theorem 4.1. *Assume that $\theta \geq \theta_\lambda$. Then S_θ is the unique solution to*

$$\min\{J_\lambda(E) : E \subset \mathcal{H} \text{ of finite perimeter, such that } |E| = |S_\theta|\}. \quad (35)$$

Proof. We split the proof into three steps.

Step 1. We start by proving that we may restrict the minimization problem (35) to spherical caps (or balls) with center on the t -axis.

Indeed, let E be an admissible competitor for (35) and denote by E^* the set obtained from E by Schwartz symmetrization about the vertical t -axis; see [13, Section 19.2]. By the definition of Schwartz symmetrization we have $\mathcal{H}^2(\partial^* E^* \cap \partial \mathcal{H}) = \mathcal{H}^2(\partial^* E \cap \partial \mathcal{H})$ and $\mathcal{H}^2(\partial^* E \cap \mathfrak{C}_{\text{top}}) \leq \mathcal{H}^2(\partial^* E^* \cap \mathfrak{C}_{\text{top}})$, hence, since $\lambda > -1$,

$$\begin{aligned} \mathcal{H}^2(\partial^* E \cap (\partial \mathcal{H} \setminus \mathfrak{C}_{\text{top}})) - \lambda \mathcal{H}^2(\partial^* E \cap \mathfrak{C}_{\text{top}}) &\geq \mathcal{H}^2(\partial^* E^* \cap (\partial \mathcal{H} \setminus \mathfrak{C}_{\text{top}})) \\ &\quad - \lambda \mathcal{H}^2(\partial^* E^* \cap \mathfrak{C}_{\text{top}}). \end{aligned}$$

Thus, by [13, Theorem 19.11] we have that $J_\lambda(E^*) < J_\lambda(E)$ unless almost every horizontal section of E (and thus $\partial^* E \cap \partial\mathcal{H}$) is equivalent to a disk. Therefore, we may restrict the minimization problem to the class of admissible competitors E such that $\partial^* E \cap \partial\mathcal{H}$ is equivalent to a (possibly degenerate) disk. Consider any such set E , and let B be the ball such that $S^+ := B \cap \mathcal{H}$ has the same volume as E and $\partial S^+ \cap \partial\mathcal{H} = \partial^* E \cap \partial\mathcal{H}$. We claim that $J_\lambda(S^+) < J_\lambda(E)$ unless E is equivalent to S^+ . To see this, we observe that if E is not equivalent to S^+ , then by the classical isoperimetric inequality we have $P(B) < P(E \cup (B \setminus S^+))$, which in turn implies $P(S^+) < P(E)$. This establishes the claim of Step 1.

Step 2. Denote by S_{opt} an optimal spherical cap (possibly coinciding with a ball). We claim $\partial S_{\text{opt}} \cap \partial\mathcal{H} \subset \mathfrak{C}_{\text{top}}$, and that $\mathcal{H}^2(\partial S_{\text{opt}} \cap \partial\mathcal{H}) > 0$.

To see this, fix a ball $B(0, R)$ such that $S_{\text{opt}} \subset\subset B(0, R)$. Arguing exactly as in Step 6 of the proof of Theorem 3.2, there exists $\Lambda > 0$ sufficiently large such that every minimizer F of the problem

$$\min\{J_\lambda(E) + \Lambda||E| - |S_\theta|| : E \subset B(0, R) \cap \mathcal{H}\}$$

satisfies the volume constraint $|F| = |S_\theta|$. Thus, S_{opt} is a minimizer of the above problem, and in turn,

$$J_\lambda(S_{\text{opt}}) \leq J_\lambda(E) + \Lambda|S_{\text{opt}} \Delta E| \quad \text{for all } E \subset B(0, R) \cap \mathcal{H}. \quad (36)$$

Then, arguing as in Step 5 of the proof of Theorem 3.2, we conclude that $\mathcal{H}^2(\partial S_{\text{opt}} \cap \mathfrak{C}_{\text{top}}) > 0$.

In order to show that $\partial S_{\text{opt}} \cap \partial\mathcal{H} \subset \mathfrak{C}_{\text{top}}$, assume by contradiction that $\partial S_{\text{opt}} \cap \partial\mathcal{H}$ is a disk $\bar{D}_r \times \{0\}$ with $r > 1$. Let $x_0 \in \partial\mathcal{H}$ belong to the relative boundary of D_r , and let $E \subset \mathbb{R}^3$ be such that $E \Delta S_{\text{opt}} \subset\subset B(x_0, (r-1)/2)$. Then, from (36), observing that in $B(x_0, (r-1)/2)$ the functional J_λ coincides with the perimeter, we have

$$\begin{aligned} P(S_{\text{opt}}; B(x_0, (r-1)/2)) &\leq P(E \cap \mathcal{H}; B(x_0, (r-1)/2)) + \Lambda|S_{\text{opt}} \Delta (E \cap \mathcal{H})| \\ &\leq P(E; B(x_0, (r-1)/2)) + \Lambda|S_{\text{opt}} \Delta E|. \end{aligned}$$

Thus, S_{opt} is a Λ -minimizer of the perimeter in $B(x_0, (r-1)/2)$. But this is impossible since Λ -minimizers of the perimeter in \mathbb{R}^3 are of class $C^{1,\alpha}$; see [13, Theorems 26.3 and 28.1]. This contradiction proves the claim.

Step 3. Assume by contradiction that $\partial S_{\text{opt}} \cap \partial\mathcal{H} = \bar{D}_r \times \{0\}$ with $r < 1$. Then, denoting by θ_{opt} the contact angle of S_{opt} , by the optimality condition we should have $\theta_{\text{opt}} = \theta_\lambda$ (see for instance [13, Theorem 19.8]). But this would imply that, up to a translation, $S_{\text{opt}} = rS_{\theta_\lambda}$. This contradicts the condition $|S_{\text{opt}}| = |S_\theta|$, since $|S_\theta| \geq |S_{\theta_\lambda}|$ by strict monotonicity of the function (34) in $(0, \pi)$. ■

Remark 4.2. Since in the above theorem we consider only variations contained in the half-space \mathcal{H} , it is clear that the shape of the lateral boundary of \mathfrak{C} below \mathcal{H} is irrelevant.

Hence the theorem would also hold with any $\mathfrak{C} \subset \mathbb{R}^3 \setminus \mathcal{H}$ (not necessarily rotationally symmetric) such that $\partial\mathfrak{C} \cap \partial\mathcal{H} = \mathfrak{C}_{\text{top}}$.

We next address the local minimality properties of S_θ also with respect to variations possibly spilling over the lateral boundary of \mathfrak{C} . We will consider separately the cases where $\theta > \frac{\pi}{2}$, $\theta = \frac{\pi}{2}$, and $\theta < \frac{\pi}{2}$. The strategy will be based on the construction of suitable calibrations, and on the use of Lemma A.1. In what follows, $(\gamma)_\varepsilon$ stands for the ε -tubular neighborhood of $\gamma = \partial D_1 \times \{0\}$. More generally, given a set $X \subset \mathbb{R}^3$ and $\varepsilon > 0$, we denote by $(X)_\varepsilon$ its ε -tubular neighborhood:

$$(X)_\varepsilon := X + B(0, \varepsilon).$$

We will often construct calibrations by considering the unit normal field to suitable foliating families of constant mean curvature surfaces. We highlight that in what follows, by *mean curvature* we mean, with a slight abuse of language, the sum of the principal curvatures. To this aim we give the following definition.

Definition 4.3. Given an open set $\Omega \subset \mathbb{R}^3$ and $\kappa \in \mathbb{R}$, a κ -foliation is a family \mathcal{F} of two-dimensional oriented analytic surfaces with constant mean curvature equal to κ , with the property that for every $x \in \Omega$ there exists a unique $\Gamma_x \in \mathcal{F}$ with $x \in \Gamma_x$.

The *normal field associated to the κ -foliation \mathcal{F}* is the vector field $\xi: \Omega \rightarrow \mathbb{S}^2$ such that for every $x \in \Omega$, $\xi(x)$ is the oriented normal to Γ_x at x .

We recall that given a vector field $\xi \in C^1(\Omega; \mathbb{R}^3)$ and a C^1 -surface $\Gamma \subset \Omega$, the tangential divergence of ξ along Γ is defined as

$$\operatorname{div}_\Gamma \xi(x) := \operatorname{div} \xi(x) - \nabla \xi(x) \nu(x) \cdot \nu(x),$$

where $\nu(x)$ is a unit normal vector to Γ at x .

We observe that if Γ is a C^2 -surface and ξ is a C^1 vector field defined in a neighborhood of Γ such that $\xi|_\Gamma$ is a unit normal to Γ , then $\operatorname{div}_\Gamma \xi(x)$ coincides with the mean curvature of Γ with respect to the orientation induced by $\xi|_\Gamma$.

Lemma 4.4. *Let $\Omega \subset \mathbb{R}^3$ be an open set and let $\kappa \in \mathbb{R}$. Let $\xi: \Omega \rightarrow \mathbb{S}^2$ be a normal field associated to a κ -foliation \mathcal{F} . Assume that ξ is of class C^1 . Then $\operatorname{div} \xi \equiv \kappa$ in Ω .*

Proof. Since $|\xi(x)|^2 = 1$ for every $x \in \Omega$, we have $0 = \nabla \xi(x) \xi(x)$. Hence, given $x \in \Omega$ and Γ_x ,

$$\begin{aligned} \operatorname{div} \xi(x) &= \operatorname{div}_{\Gamma_x} \xi(x) + (\nabla \xi(x) \xi(x)) \cdot \xi(x) \\ &= \operatorname{div}_{\Gamma_x} \xi(x) = \kappa \end{aligned}$$

since ξ restricted to Γ_x coincides with the oriented normal field to Γ_x . ■

We start by a local minimality result for S_θ in the case $\lambda \in (0, 1)$, that is, $\theta_\lambda \in (0, \frac{\pi}{2})$.

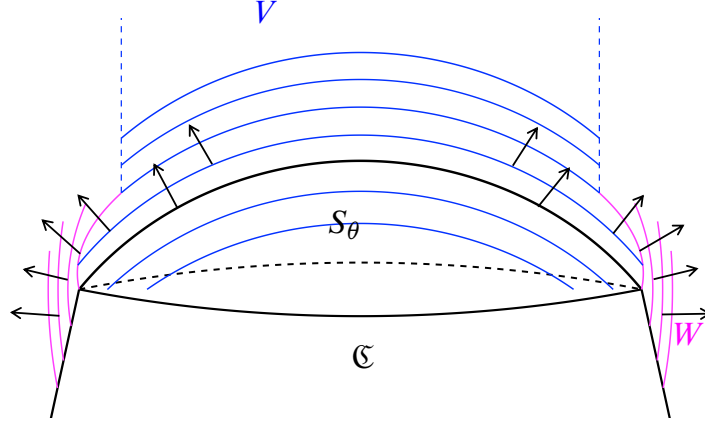

Figure 2. The foliations constructed in the proof of Theorem 4.5. The foliation defined in V is shown in blue, and the one defined in W in magenta.

Theorem 4.5 (Case $\theta < \frac{\pi}{2}$). *Assume*

$$0 < \theta_\lambda < \theta < \frac{\pi}{2} \quad \text{and} \quad \theta < \left(\frac{\pi}{2} - \alpha\right) + \theta_\lambda. \quad (37)$$

Given $M > 0$, there exists an open set \mathcal{O} containing $(\bar{S}_\theta \cup \mathcal{C}) \cap \{t > -M\}$ such that

$$J_\lambda(S_\theta) \leq J_\lambda(E) \quad (38)$$

for every $E \subset \mathcal{O} \setminus \mathcal{C}$, with $|E| = |S_\theta|$, and

$$(\partial S_\theta \setminus \partial^* E) \cap \mathcal{C}_{\text{top}} \subset (\gamma)_\varepsilon \quad (39)$$

for some ε depending only on θ and λ . Moreover, inequality (38) is strict provided $|E \Delta S_\theta| > 0$.

Proof. Fix $b \in (\tan(\theta - \frac{\pi}{2}), \tan(\theta_\lambda - \alpha))$, $b > -\tan \alpha$. This is possible thanks to (37). We now apply Lemma A.4 below to construct a family of solutions $(g(\sigma, \cdot))_{\sigma \in (-M-1/2, 1/2)}$ of (77), with $H = 2/R_\theta$ and $f(\sigma) = 1 - \sigma \tan \alpha$, each of them defined and positive in the interval $(\sigma - \bar{\eta}, \sigma + \bar{\eta})$ whose graphs foliate an open neighborhood of $\{(f(\sigma), \sigma) : \sigma \in [-M, 0]\}$. Note that this is possible since $f'(\sigma) = -\tan \alpha \neq b$.

To visualize the construction below the reader may refer to Figure 2. Consider the corresponding family $(\Sigma_\sigma)_{\sigma \in (-M-1/2, 1/2)}$ of surfaces of revolutions defined by

$$\Sigma_\sigma := \{(x', t) \in \mathbb{R}^3 : |x'| = g(\sigma, t), t \in (\sigma - \bar{\eta}, \sigma + \bar{\eta})\}, \quad (40)$$

which foliate an open set \tilde{W} containing a tubular neighborhood of the form $(\mathcal{C}_{\varepsilon_1} \setminus \mathcal{C}) \cap \{-M \leq t \leq 0\}$ for some $\varepsilon_1 > 0$ depending on M . We orient Σ_σ in such a way that the corresponding normal ν_{Σ_σ} is outward with respect to the set $G_\sigma := \{(x', t) \in \mathbb{R}^3 : |x'| < g(\sigma, t)\}$. With such an orientation, by Remark A.3 we have that Σ_σ has constant mean curvature equal to $2/R_\theta$.

Since by construction $\frac{\partial g(\sigma, t)}{\partial t}|_{t=\sigma} = b$ and $b < \tan(\theta_\lambda - \alpha)$, the contact angle of Σ_σ with the lateral boundary of \mathfrak{C} is less than θ_λ for $\sigma \in (-M, 0)$. Therefore,

$$\nu_{\Sigma_\sigma} \cdot \nu_{\mathfrak{C}} > \lambda \quad \text{on the lateral boundary of } \mathfrak{C} \quad (41)$$

for all $\sigma \in (-M, 0)$. Moreover, the fact that $b > \tan(\theta - \frac{\pi}{2})$ implies that $\Sigma_0 \setminus \mathfrak{C}$ lies outside \bar{S}_θ , provided $\bar{\eta}$ is sufficiently small. In turn, $\Sigma_\sigma \setminus \mathfrak{C}$ lies outside \bar{S}_θ for all $\sigma \in (-M, 0)$.

We want to define a calibration in an open set U containing \bar{S}_θ . We define the set

$$V := (G_0 \cap \{(x', t) : 0 < t < \bar{\eta}\}) \cup (D_{g(0, \bar{\eta})} \times [\bar{\eta}, +\infty)).$$

In order to define the calibration in V , consider the family of hemispheres $\Gamma_t := \partial B_{e_3}^+(te_3, R_\theta)$ (see (31)), $t \in \mathbb{R}$, which defines a $2/R_\theta$ -foliation of V , provided $g(0, \bar{\eta}) < R_\theta$ (which is certainly true if $\bar{\eta}$ is sufficiently small). Then consider the associated outer normal field ξ_V (see Definition 4.3), so that $\operatorname{div} \xi = 2/R_\theta$. Note, in particular, that, since $\arccos \lambda = \theta_\lambda < \theta < \pi/2$,

$$\xi_V \cdot e_3 = \cos \theta < \lambda \quad \text{on } \gamma, \quad (42)$$

hence the strict inequality still holds in $\mathfrak{C}_{\text{top}} \cap (\gamma)_\varepsilon$, provided ε is small enough. To complete the definition we set

$$W := (\tilde{W} \cap (\mathfrak{C}_{\varepsilon_1} \setminus \mathfrak{C})) \setminus (V \cup \Sigma_0),$$

where \tilde{W} is the open set foliated by the family (40). Observe that W satisfies (64) of Lemma A.1. Let ξ_W be the oriented normal field associated with the foliation $(\Sigma_\sigma)_{(-M-1/2, 0)}$, according to Definition 4.3 and note that ξ_W satisfies assumption (63). Finally, set $U := V \cup W \cup (\Sigma_0 \cap \mathfrak{C}_{\varepsilon_1})$, $\mathcal{O} := (U \cup \mathfrak{C}) \cap \{t > -M\}$ and observe that \mathcal{O} contains $(\bar{S}_\theta \cup \mathfrak{C}) \cap \{t > -M\}$. Define the calibration

$$\xi := \begin{cases} \xi_V & \text{in } V, \\ \xi_W & \text{on } W, \end{cases}$$

and note that it satisfies by construction all the assumptions of Lemma A.1, including those ensuring the strict local minimality. Thus the conclusion of the theorem follows. ■

Remark 4.6. Note that if $\theta = \theta_\lambda$, then (42) holds with the equality and thus we cannot find $\varepsilon > 0$ such that $\xi_V \cdot e_3 \leq \lambda$ on $\mathfrak{C}_{\text{top}} \cap (\gamma)_\varepsilon$. Thus the above construction implies that (38) holds for every $E \subset \mathcal{O} \setminus \mathfrak{C}$, with $|E| = |S_\theta|$ such that $\mathfrak{C}_{\text{top}} \subset \partial^* E$. However, we expect that S_{θ_λ} is a global minimizer. But proving this fact would require extending the isoperimetric inequality outside convex sets established in [4] to the case $\lambda \neq 0$.

Remark 4.7. Note that if $\alpha < \theta_\lambda$, we may choose b in the previous proof to be positive. In turn, \mathcal{O} contains a set of the form $(D_{1+\delta} \times (-M, +\infty)) \setminus \mathfrak{C}$ for a suitable $\delta > 0$ sufficiently small. Note that this is always possible when $\alpha = 0$.

Remark 4.8 (The case $\theta = (\frac{\pi}{2} - \alpha) + \theta_\lambda$). The calibration in the previous proof works also if the second inequality in (37) is replaced by equality, provided we choose $b = \tan(\theta_\lambda - \alpha)$. The only difference here is that now $\Sigma_0 \subset \partial S_\theta$ and the open set U contains the closure of S_θ except for the horizontal circle (lying on ∂S_θ) generated by the end point of $\Sigma_0 \cap \{(x', t) : t < \bar{\eta}\}$. Since now the calibration ξ is continuous on Σ_0 , by Remark A.2 we obtain again that S_θ is a local minimizer with respect to volume-preserving variations that are contained in U (and satisfying (39)). However, in this case, (41) holds as an equality and the strict minimality of S_θ is not clear.

Remark 4.9. The condition $\theta \leq (\frac{\pi}{2} - \alpha) + \theta_\lambda$ in (37) is the one preventing the occurrence of spillover on the lateral boundary of \mathbb{C} . We will show below (see Proposition 4.14) that if such a condition is violated then there exists a competitor with nonempty and arbitrarily small spillover region having less energy than S_θ ; see also [16].

We now turn to the case $\theta = \frac{\pi}{2}$ and $\theta_\lambda < \frac{\pi}{2}$. Note that in this case the calibration will be defined in an open set containing \bar{S}_θ minus a parallel.

Theorem 4.10 (Case $\theta = \frac{\pi}{2}$). *Assume*

$$0 \leq \alpha < \theta_\lambda < \frac{\pi}{2}. \quad (43)$$

Given $M > 0$ and $\tau \in (0, 1)$, there exists an open set \mathcal{O} containing $((\bar{S}_{\frac{\pi}{2}} \cup \mathbb{C}) \cap \{t > -M\}) \setminus (\partial S_{\frac{\pi}{2}} \cap \{t = \tau\})$ such that

$$J_\lambda(S_{\frac{\pi}{2}}) \leq J_\lambda(E) \quad (44)$$

for every $E \subset \mathcal{O} \setminus \mathbb{C}$ with finite perimeter, $|E| = |S_{\frac{\pi}{2}}|$, and

$$(\partial S_{\frac{\pi}{2}} \setminus \partial^* E) \cap \mathbb{C}_{\text{top}} \subset (\gamma)_\varepsilon$$

for some ε depending only on λ . Moreover, inequality (44) is strict provided $|E \Delta S_{\frac{\pi}{2}}| > 0$.

Proof. Once again the strategy is to construct a suitable calibration. Note that $H = 2/R_{\pi/2} = 2$. We apply Lemma A.5 with $\delta < 0$, such that $t(\delta, \pi/2) > \tau$. This is possible thanks to (81). Thus, we get $\beta > 0$ such that the family $g_{a,b}^\delta$, where $a = g_{\frac{\pi}{2}}^\delta(\delta)$ and $b \in (g_{\frac{\pi}{2}}^\delta(\delta) - \beta, g_{\frac{\pi}{2}}^\delta(\delta) + \beta)$, with $g_{\frac{\pi}{2}}^\delta(\delta)$ defined in (79), foliates the open set

$$\left\{ (t, u) : t \in (\delta/2, t(\delta, \frac{\pi}{2})), g_{a, g_{\frac{\pi}{2}}^\delta(\delta) - \beta}^\delta(t) < u < g_{a, g_{\frac{\pi}{2}}^\delta(\delta) + \beta}^\delta(t) \right\}.$$

In turn, the surfaces of revolution

$$\begin{aligned} \Gamma_b &:= \left\{ (x', t) \in \mathbb{R}^3 : |x'| = g_{a,b}^\delta(t), t \in (\delta/2, t(\delta, \frac{\pi}{2})) \right\} \subset \partial G_b, \\ b &\in (g_{\frac{\pi}{2}}^\delta(\delta) - \beta, g_{\frac{\pi}{2}}^\delta(\delta) + \beta), \end{aligned} \quad (45)$$

where

$$G_b := \left\{ (x', t) \in \mathbb{R}^3 : |x'| < g_{a,b}^\delta(t), t \in (\delta/2, t(\delta, \frac{\pi}{2})) \right\},$$

foliate an open set. In particular, the set

$$\tilde{U}_\tau := \left\{ (x', t) \in \mathbb{R}^3 : t \in (\delta/2, \tau), g_{a, g'_{\frac{\pi}{2}}(\delta) - \beta}^\delta(t) < |x'| < g_{a, g'_{\frac{\pi}{2}}(\delta) + \frac{\beta}{2}}^\delta(t) \right\} \subset G_b \quad (46)$$

is an open set containing $(\partial S_{\frac{\pi}{2}} \cap \{0 < t < \tau\}) \cup \gamma$. Denoting by $\nu_{\mathbb{C}}$ the exterior normal to the lateral boundary of \mathbb{C} , from (43) we have that $\nu_{S_{\frac{\pi}{2}}}(x) \cdot \nu_{\mathbb{C}}(x) > \lambda$ for every $x \in \gamma$. Therefore, taking β smaller, if needed, we may assume that

$$\nu_{G_b}(x) \cdot \nu_{\mathbb{C}}(x) > \lambda \quad \text{for every } x \in \Gamma_b \cap \partial\mathbb{C} \text{ and } b \in (g'_{\frac{\pi}{2}}(\delta), g'_{\frac{\pi}{2}}(\delta) + \frac{\beta}{2}]. \quad (47)$$

Let $\sigma_0 \in (\delta/2, 0)$ be such that

$$g_{a, g'_{\frac{\pi}{2}}(\delta) + \frac{\beta}{2}}^\delta(\sigma_0) = 1 - \sigma_0 \tan \alpha.$$

Then let I be an open interval containing σ_0 and $-M$. We now apply Lemma A.4 with

$$b = \frac{d}{dt} g_{a, g'_{\frac{\pi}{2}}(\delta) + \frac{\beta}{2}}^\delta(\sigma) = g'_{\frac{\pi}{2}}(\delta) + \frac{\beta}{2}, \quad f(\sigma) = 1 - \sigma \tan \alpha$$

to get a family of functions $g(\sigma, t)$, $\sigma \in I$, defined for $t \in (\sigma - \eta, \sigma + \eta)$, such that

$$g(\sigma_0, \cdot) = g_{a, g'_{\frac{\pi}{2}}(\delta) + \frac{\beta}{2}}^\delta(\cdot),$$

satisfying (77). Note that with our choice of b we have $b > -\tan \alpha$. Also, we may assume that η satisfies $\sigma_0 + \eta < \tau$. In particular, the graphs of $(g(\sigma, \cdot))_{\sigma \in (-M, \sigma_0)}$ foliate an open set.

We now set

$$\Psi_\sigma := \{(x', t) \in \mathbb{R}^3 : |x'| = g(\sigma, t), t \in (\sigma - \eta, \sigma + \eta)\} \subset \partial\Phi_\sigma, \quad \sigma \in (-M, \sigma_0], \quad (48)$$

where

$$\begin{aligned} \Phi_\sigma &:= \{(x', t) \in \mathbb{R}^3 : |x'| < g(\sigma, t), t \in (\sigma - \eta, \sigma + \eta)\}, \\ A &:= \bigcup_{\sigma \in (-M, \sigma_0]} \Psi_\sigma. \end{aligned}$$

Then we set

$$\begin{aligned} U_\tau &:= ((\tilde{U}_\tau \cup A) \setminus \mathbb{C}) \cup S_{\frac{\pi}{2}} \cup (D_{\sqrt{1-\tau^2}} \times [\tau, +\infty)), \\ \mathcal{O} &:= U_\tau \cup (\mathbb{C} \cap \{t > -M\}), \end{aligned}$$

where \tilde{U}_τ is defined in (46), and note that \mathcal{O} contains $((\bar{S}_{\frac{\pi}{2}} \cup \mathbb{C}) \cap \{t > -M\}) \setminus (\partial S_{\frac{\pi}{2}} \cap \{t = \tau\})$; see Figure 3. We denote by $\xi_{S_{\frac{\pi}{2}}} : D_1 \times \mathbb{R} \mapsto \mathbb{R}^3$ the outer normal field associated with the family of foliating hemispheres $(\partial B_{e_3}^+(te_3, 1))_{t \in \mathbb{R}}$ (see (31)), so that $\operatorname{div} \xi_{S_{\frac{\pi}{2}}} = 2$, by $\xi_{\tilde{U}_\tau}$ the outer (with respect to G_b) normal vector field associated with the foliation (45),

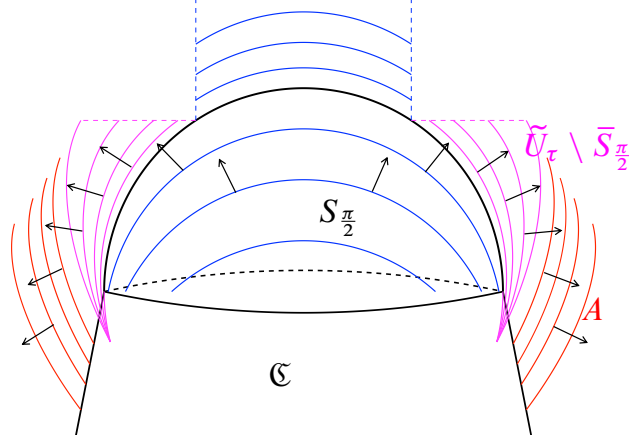

Figure 3. The foliations constructed in the proof of Theorem 4.10. The foliation defined in $\tilde{U}_\tau \setminus \bar{S}_{\pi/2}$ is shown in magenta and the foliation defined in A in red. The foliation in the remaining part of \mathfrak{C} is in blue.

and by ξ_A the outer (with respect to Φ_σ) normal vector field associated with the foliation (48). Denoting $x_0 = (0, f(\sigma_0), \sigma_0)$, by construction on $\partial\mathfrak{C} \cap \bar{A}$ we have

$$\xi_A \cdot \nu_{\mathfrak{C}} = \nu_{\Phi_\sigma} \cdot \nu_{\mathfrak{C}} = \nu_{\Phi_{\sigma_0}}(x_0) \cdot \nu_{\mathfrak{C}}(x_0) > \lambda,$$

thanks to (47) and to the fact that $\frac{d}{dt}g'(\sigma, \cdot)|_{t=\sigma} = g'_{\frac{\pi}{2}}(\delta) + \frac{\beta}{2}$. Note also that since $\theta_\lambda < \frac{\pi}{2}$ we have

$$\xi_{S_{\frac{\pi}{2}}} \cdot \nu_{\mathfrak{C}} < \lambda \quad \text{on } \mathfrak{C}_{\text{top}} \cap (\gamma)_\varepsilon,$$

provided that $\varepsilon > 0$ is sufficiently small. For $x \in U_\tau$ we set

$$\xi(x) := \begin{cases} \xi_{\tilde{U}_\tau}(x) & \text{if } x \in \tilde{U}_\tau \setminus \bar{S}_{\frac{\pi}{2}}, \\ \xi_A(x) & \text{if } x \in A, \\ \xi_{S_{\frac{\pi}{2}}}(x) & \text{otherwise.} \end{cases}$$

Observe that, setting $V := U_\tau \cap \{t > 0\}$, $\Sigma_0 := U_\tau \cap \{t = 0\}$, and $W := U_\tau \cap \{t < 0\}$, all the assumptions of Lemma A.1 are satisfied, including those ensuring the strict local minimality. Thus the conclusion of the theorem follows. \blacksquare

We conclude with the case $\frac{\pi}{2} < \theta < \pi$. In this case our technique based on calibrations yields local minimality only with respect to competitors that coincide with S_θ in a neighborhood of the north pole. It is an open problem whether a stronger local minimality property holds true also in this case.

Theorem 4.11 (Case $\frac{\pi}{2} < \theta < \pi$). *Assume*

$$0 \leq \alpha < \theta_\lambda < \theta, \quad \frac{\pi}{2} < \theta < \left(\frac{\pi}{2} - \alpha\right) + \theta_\lambda. \quad (49)$$

Set $H = 2/R_\theta$. Let $t(0, \theta) \in (-2 \cos \theta/H, 2(1 - \cos \theta)/H]$ be as in Lemma A.5. Then for every $M > 0$, $\tau \in (-2 \cos \theta/H, t(0, \theta))$ there exists an open set \mathcal{D} containing $\partial(S_\theta \cup \mathbb{C}) \cap \{-M < t < \tau\}$ such that

$$J_\lambda(S_\theta) \leq J_\lambda(E) \quad (50)$$

for every $E \subset \mathbb{R}^3 \setminus \mathbb{C}$, with $|E| = |S_\theta|$ and

$$E \Delta S_\theta \subset\subset \mathcal{D}. \quad (51)$$

Moreover, inequality (50) is strict provided $|E \Delta S_\theta| > 0$.

Proof. Let τ be as in the statement and let $-2(1 + \cos \theta)/H < \delta < 0$ be such that $t(\delta, \theta) > \tau$. This is possible thanks to the lower semicontinuity of $t(\cdot, \cdot)$; see Lemma A.5. From the same lemma we obtain that there exists $\beta > 0$ and an open neighborhood $(\partial S_\theta \cap \{0 < t < \tau\}) \cup \gamma$ foliated by the family of surfaces of revolution

$$\begin{aligned} \Gamma_b &:= \{(x', t) \in \mathbb{R}^3 : |x'| = g_{a,b}^\delta(t), t \in (\delta/2, \tau)\} \subset \partial G_b, \\ b &\in (g'_\theta(\delta) - \beta, g'_\theta(\delta) + \beta), \end{aligned} \quad (52)$$

where

$$G_b := \{(x', t) \in \mathbb{R}^3 : |x'| < g_{a,b}^\delta(t), t \in (\delta, \tau)\},$$

with $a := g_\theta(\delta)$. Note also that by construction,

$$\partial S_\theta \cap (\mathbb{R}^2 \times (0, \tau)) = \Gamma_{g'_\theta(\delta)} \cap (\mathbb{R}^2 \times (0, \tau)).$$

Denoting by $\nu_{\mathbb{C}}$ the exterior normal to the lateral boundary of \mathbb{C} , from (49) we have

$$\nu_{S_\theta}(x) \cdot e_3 < \lambda, \quad \nu_{S_\theta}(x) \cdot \nu_{\mathbb{C}}(x) > \lambda \quad \text{for every } x \in \gamma.$$

Therefore, taking β smaller, if needed, we may assume that

$$\begin{aligned} \nu_{G_b}(x) \cdot \nu_{\mathbb{C}}(x) &< \lambda \quad \text{for every } x \in \mathbb{C}_{\text{top}} \cap \Gamma_b \text{ and } b \in (g'_\theta(\delta) - \beta, g'_\theta(\delta)), \\ \nu_{G_b}(x) \cdot \nu_{\mathbb{C}}(x) &> \lambda \quad \text{for every } x \in \Gamma_b \cap \partial \mathbb{C} \text{ and } b \in (g'_\theta(\delta), g'_\theta(\delta) + \frac{\beta}{2}). \end{aligned} \quad (53)$$

As in the proof of Theorem 4.10, we set

$$\tilde{U}_\tau := \left\{ (x', t) \in \mathbb{R}^3 : t \in (\delta/2, \tau), g_{a, g'_\theta(\delta) - \beta}^\delta(t) < |x'| < g_{a, g'_\theta(\delta) + \frac{\beta}{2}}^\delta(t) \right\}$$

and define $\xi_{\tilde{U}_\tau}$ as the outer (with respect to G_b) normal vector field associated with the foliation (52). We define the set A and the vector field ξ_A as in the proof of Theorem 4.10, with the function $g_{a, g'_\theta(\delta) + \frac{\beta}{2}}^\delta$ replaced by $g_{a, g'_\theta(\delta) + \frac{\beta}{2}}^\delta$. Set $\mathcal{D} := \tilde{U}_\tau \cup A$ (see Figure 4),

$U_\tau := \mathcal{D} \setminus \mathbb{C}$, and let $\xi: U_\tau \mapsto \mathbb{R}^3$ be the vector field coinciding with $\xi_{\tilde{U}_\tau}$ in $U_\tau \cap \tilde{U}_\tau$ and with ξ_A in $U_\tau \cap A$.

Observe that, setting $V := U_\tau \cap \{t > 0\}$, $\Sigma_0 := U_\tau \cap \{t = 0\}$, and $W := U_\tau \cap \{t < 0\}$, all the assumptions of Lemma A.1 are satisfied, including those ensuring the strict local minimality (see (53)). Thus the conclusion of the theorem follows. \blacksquare

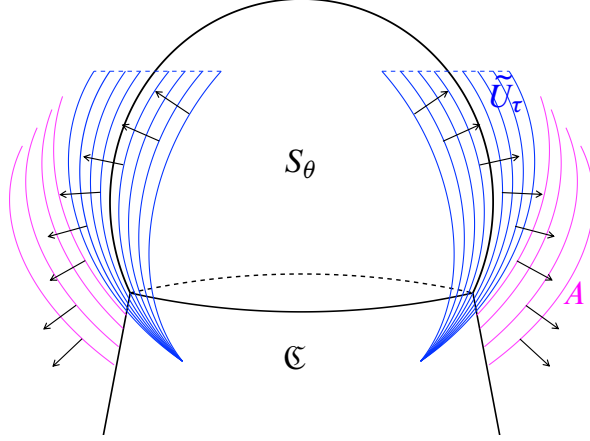

Figure 4. The foliations defined in Theorem 4.11.

Remark 4.12 (The limit case $\theta = (\frac{\pi}{2} - \alpha) + \theta_\lambda$). In the limit case $\theta = (\frac{\pi}{2} - \alpha) + \theta_\lambda$, the above construction still works. The second strict inequality in (53) is now replaced by an equality. Therefore, we may still conclude that S_θ is a local minimizer with respect to competitors satisfying the mass constraint and (51). However, we are not able to deduce the strict local minimality of S_θ .

Remark 4.13. We first note that under the assumption of Theorem 4.11 the condition $\theta \leq (\frac{\pi}{2} - \alpha) + \theta_\lambda$ prevents the spillover on \mathfrak{C} ; see Remark 4.9.

Note also in this case that the spherical cap S_θ is an isolated local minimizer with respect to small L^∞ perturbations that leave unchanged a neighborhood of the north pole. However, recalling (81), such a neighborhood can be made smaller and smaller as θ gets closer and closer to $\pi/2$.

We conclude this section by showing that when the condition $\theta \leq \frac{\pi}{2} - \alpha + \theta_\lambda$ (see (37), (49), and Remarks 4.8 and 4.12) is violated, there are configurations arbitrarily close to S_θ spilling over the lateral boundary of \mathfrak{C} and with strictly lower energy.

Proposition 4.14. *Assume*

$$\theta > \frac{\pi}{2} - \alpha + \theta_\lambda. \quad (54)$$

Then there exists a one-parameter family $(\Phi_t)_{t \in (0, \varepsilon)}$ of diffeomorphisms converging to the identity in C^1 such that, setting $E_t := \Phi_t(S_\theta)$, $E_t \subset \mathbb{R}^3 \setminus \mathfrak{C}$, $|E_t| = |S_\theta|$, $\mathfrak{C}_{\text{top}}$ belongs to the relative interior of $\partial E_t \cap \mathfrak{C}$ and $J_\lambda(E_t) < J_\lambda(S_\theta)$.

Proof. First observe that due to assumption (54) we may find an axially symmetric (non-spherical) closed cap $\mathfrak{S} \subset \bar{S}_\theta$ such that $\partial \mathfrak{S} \cap \partial S_\theta = \mathfrak{C}_{\text{top}}$ and $\tilde{\mathfrak{C}} := \mathfrak{C} \cup \mathfrak{S}$ is of class C^∞ ; see Figure 5. Without loss of generality, we may assume that

$$\tilde{\mathfrak{C}} := \{(x', t) : |x'| \leq g(t), t \in (-\infty, t_\alpha]\},$$

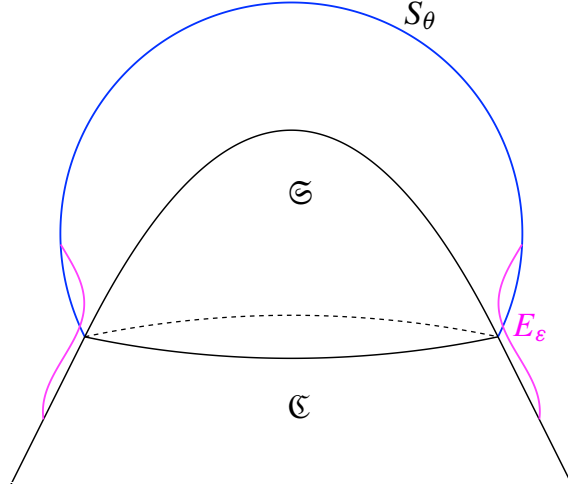

Figure 5. The sets E_ε and \mathfrak{S} constructed in the proof of Proposition 4.14.

where the function g is continuous, $t_\alpha > 0$, $g(t_\alpha) = 0$, and $g \in C^\infty(-\infty, t_\alpha)$. Recall $g(t) = 1 - t \tan \alpha$ for $t \leq 0$.

We denote by $\Gamma_g \subset \mathbb{R}^2 := \{(s, t) : s, t \in \mathbb{R}\}$, the graph of g with respect to the vertical t -axis, that is,

$$\Gamma_g := \{(g(t), t) : t \in (-\infty, t_\alpha]\}$$

and by $\tilde{Y} : \Gamma_g \rightarrow \mathbb{R}^2$ a C^∞ tangent vector field such that

$$\begin{aligned} \tilde{Y}(g(t), t) &:= (\tan \alpha, -1) && \text{for } t \leq 0, \\ \tilde{Y}(g(t), t) &:= 0 && \text{for } \frac{t_\alpha}{2} \leq t \leq t_\alpha. \end{aligned} \tag{55}$$

Let $A \subset \mathbb{R}^2$ denote the open set $A := ((0, +\infty) \times \mathbb{R}) \setminus S_g$, where S_g is the closed (vertical) subgraph of g . We extend \tilde{Y} to a vector field $Y = (Y_1, Y_2)$ defined in A by setting

$$Y_2(s, t) := \begin{cases} \tilde{Y}_2(g(t), t) & \text{if } t \leq t_\alpha, \\ 0 & \text{otherwise,} \end{cases}$$

and

$$Y_1(s, t) := \begin{cases} \frac{1}{s} \left[\tilde{Y}_1(g(t), t)g(t) + \frac{1}{2} \frac{\partial}{\partial t} (\tilde{Y}_2(g(t), t))g^2(t) \right] \\ -\frac{1}{2} \frac{\partial}{\partial t} (\tilde{Y}_2(g(t), t))s \\ 0 \end{cases} \begin{array}{l} \text{if } t \leq t_\alpha, \\ \\ \text{otherwise.} \end{array}$$

Observe that, by construction,

$$\frac{\partial Y_1}{\partial s} + \frac{\partial Y_2}{\partial t} = -\frac{Y_1}{s}. \tag{56}$$

Let $X \in C^\infty(\overline{\mathbb{R}^3 \setminus \mathfrak{C}}; \mathbb{R}^3)$ be the vector field defined in $\mathbb{R}^3 \setminus \mathfrak{C}$ by

$$X(x', t) := \left(Y_1(|x'|, t) \frac{x'}{|x'|}, Y_2(|x'|, t) \right).$$

Note that by the tangential character of \tilde{Y} and by (56), it can be shown that

$$\operatorname{div} X = 0 \text{ in } \mathbb{R}^3 \setminus \tilde{\mathfrak{C}}, \quad X \cdot \nu_{\tilde{\mathfrak{C}}} = 0 \text{ on } \partial \tilde{\mathfrak{C}}, \quad (57)$$

and, recalling (55),

$$X(x', 0) = (x' \tan \alpha, -1) \text{ on } \gamma. \quad (58)$$

In particular,

$$|X| = \frac{1}{\cos \alpha} \text{ on } \gamma. \quad (59)$$

Consider now the flow Φ associated with X , that is, the solution to

$$\begin{cases} \frac{\partial \Phi}{\partial \varepsilon} = X(\Phi), \\ \Phi(0, x) = x, \end{cases}$$

and set

$$E_\varepsilon := \Phi(\varepsilon, S_\theta \setminus \mathfrak{C}) \cup (\mathfrak{C} \setminus \mathfrak{C}_{\text{top}}).$$

Note that by (57) we have $|E_\varepsilon| = |S_\theta|$ and $\partial E_\varepsilon \setminus \mathfrak{C} \subset \mathbb{R}^3 \setminus \tilde{\mathfrak{C}}$. On the other hand, by (57)₂, (58), and the axial symmetry of X , we have that for t small enough the contact line $\gamma_\varepsilon = \Phi(\varepsilon, \gamma)$ of E_ε with \mathfrak{C} is a horizontal circle lying below γ . In particular, $\mathfrak{C}_{\text{top}}$ belongs to the relative interior of $\partial E_\varepsilon \cap \mathfrak{C}$. By the area formula [2, Theorem 2.71],

$$J_\lambda(E_\varepsilon) = \int_{\partial S_\theta \setminus \mathfrak{C}_{\text{top}}} J\Phi(\varepsilon, x) d\mathcal{H}^2(x) - \lambda \mathcal{H}^2(\Sigma_\varepsilon) - \lambda \mathcal{H}^2(\mathfrak{C}_{\text{top}}),$$

where $J\Phi(\varepsilon, \cdot)$ is the tangential Jacobian of $\Phi(\varepsilon, \cdot)$ on ∂E_ε and $\Sigma_\varepsilon \subset \partial \mathfrak{C} \setminus \mathfrak{C}_{\text{top}}$ is the lateral boundary of the truncated cone lying between γ and γ_ε . Differentiating with respect to ε , denoting by σ_γ the outer conormal to γ with respect to S_θ , and recalling (59), by the divergence theorem on manifolds with boundary [13, Theorem 11.8] we get

$$\begin{aligned} \frac{d}{d\varepsilon} J_\lambda(E_\varepsilon)|_{\varepsilon=0} &= \int_{\partial S_\theta \setminus \mathfrak{C}_{\text{top}}} \operatorname{div}_\tau X d\mathcal{H}^2 - \frac{2\pi\lambda}{\cos \alpha} \\ &= \frac{2}{R_\theta} \int_{\partial S_\theta \setminus \mathfrak{C}_{\text{top}}} X \cdot \nu_{S_\theta} d\mathcal{H}^2 + \int_\gamma X \cdot \sigma_\gamma d\mathcal{H}^1 - \frac{2\pi\lambda}{\cos \alpha} \\ &= \int_\gamma X \cdot \sigma_\gamma d\mathcal{H}^1 - \frac{2\pi\lambda}{\cos \alpha}, \end{aligned} \quad (60)$$

where in the last equality we used

$$\frac{2}{R_\theta} \int_{\partial S_\theta \setminus \mathfrak{C}_{\text{top}}} X \cdot \nu_{S_\theta} d\mathcal{H}^2 = \frac{2}{R_\theta} \int_{\partial(S_\theta \setminus \tilde{\mathfrak{C}})} X \cdot \nu_{S_\theta \setminus \tilde{\mathfrak{C}}} d\mathcal{H}^2 = 0,$$

thanks to (57). Observing that the conormal σ_γ is given by $(-x' \cos(\pi - \theta), -\sin(\pi - \theta))$ and recalling (58), we have from (60) that

$$\begin{aligned} \frac{d}{d\varepsilon} J_\lambda(E_\varepsilon)|_{\varepsilon=0} &= \frac{2\pi}{\cos \alpha} [\sin(\pi - \theta) \cos \alpha - \sin \alpha \cos(\pi - \theta) - \lambda] \\ &= \frac{2\pi}{\cos \alpha} [\sin(\pi - \theta - \alpha) - \cos \theta_\lambda] \\ &= \frac{2\pi}{\cos \alpha} \left[\cos\left(\theta + \alpha - \frac{\pi}{2}\right) - \cos \theta_\lambda \right] < 0, \end{aligned}$$

where the last inequality follows from (54) and the fact that $\alpha \in (0, \frac{\pi}{2})$, $\theta \in (0, \pi)$. \blacksquare

A. Technical lemmas

We start with a technical lemma that has been used in the previous section to construct calibrations.

Lemma A.1 (Calibrations). *Let $\theta \in (0, \pi)$ and let $U \subset \mathbb{R}^3 \setminus \mathfrak{C}$ be an open set such that*

$$U = V \cup W \cup \Sigma_0,$$

where V and W are open and disjoint, $S_\theta \cap U \subset V \subset \mathcal{H}$, and $\Sigma_0 := \partial V \cap \partial W \cap U$ is a nonempty C^1 -surface contained in $\bar{\mathcal{H}} \setminus \bar{S}_\theta$. Let $\xi: \bar{U} \setminus \Sigma_0 \rightarrow \mathbb{R}^3$ be a vector field satisfying the following properties:

- (i) $\xi|_V$ and $\xi|_W$ are both Lipschitz continuous vector fields in $V \setminus (\gamma)_\delta$ and $W \setminus (\gamma)_\delta$ for every $\delta > 0$, respectively;
- (ii) $\operatorname{div} \xi \leq 2/R_\theta$ in $(U \setminus \Sigma_0) \cap S_\theta$ and $\operatorname{div} \xi \geq 2/R_\theta$ in $U \setminus (\Sigma_0 \cup S_\theta)$;
- (iii) $\xi|_V \cdot \nu_{\Sigma_0} \leq \xi|_W \cdot \nu_{\Sigma_0}$ on Σ_0 , where ν_{Σ_0} is unit normal field to Σ_0 pointing towards W ;
- (iv) $\xi = \nu_{S_\theta}$ on $\partial S_\theta \cap U$;
- (v) $\|\xi\|_\infty \leq 1$;
- (vi) $\xi \cdot \nu_{\mathfrak{C}} \leq \lambda$ on $\mathfrak{C}_{\text{top}} \cap (\gamma)_\varepsilon \cap \partial U$ and $\xi \cdot \nu_{\mathfrak{C}} \geq \lambda$ on $(\partial \mathfrak{C} \setminus \mathfrak{C}_{\text{top}}) \cap \partial U$ for some $\varepsilon > 0$.

Then

$$J_\lambda(S_\theta) \leq J_\lambda(E) \tag{61}$$

for every $E \subset \mathbb{R}^3 \setminus \mathfrak{C}$, with $|E| = |S_\theta|$, $E \Delta S_\theta \subset U$, and

$$\mathfrak{C}_{\text{top}} \setminus \partial^* E \subset (\gamma)_\varepsilon. \tag{62}$$

Moreover, if the second inequality in (vi) is strict and

$$\xi|_W(x', t) \cdot (x', 0) \geq 0 \tag{63}$$

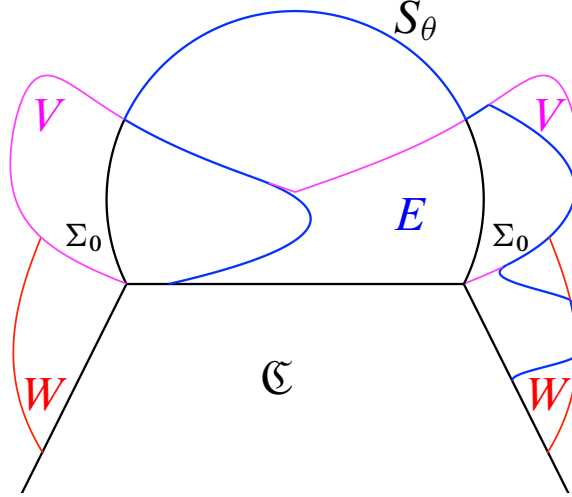

Figure 6. A set E satisfying the assumptions of Lemma A.1: $E \Delta S_\theta \subset V \cup W \cup \Sigma_0$, $|E| = |S_\theta|$.

for all $(x', t) \in W$, and if it holds that

$$\begin{aligned} (x', t) &\in \partial \mathcal{C} \setminus \mathcal{C}_{\text{top}} \\ &\Rightarrow W \cap \{(sx', t) : s \geq 1\} \text{ is a (possibly degenerate) line segment,} \end{aligned} \quad (64)$$

then the inequality in (61) is strict whenever $|E \Delta S_\theta| > 0$.

Proof. Let E be an admissible set; see Figure 6. Since E and S_θ have the same volume (and thus $|E \setminus S_\theta| = |S_\theta \setminus E|$) and (ii) holds, we have

$$\int_{S_\theta \setminus E} \operatorname{div} \xi \, dx \leq \int_{E \setminus S_\theta} \operatorname{div} \xi \, dx. \quad (65)$$

Assume now that $\xi|_V$ and $\xi|_W$ are Lipschitz continuous vector fields in their domains. Write

$$\int_{E \setminus S_\theta} \operatorname{div} \xi \, dx = \int_{(E \setminus S_\theta) \cap V} \operatorname{div} \xi \, dx + \int_{(E \setminus S_\theta) \cap W} \operatorname{div} \xi \, dx$$

and observe that since $E \Delta S_\theta \subset U$ and Σ_0 is a surface of class C^1 , the sets $(E \setminus S_\theta) \cap V$ and $(E \setminus S_\theta) \cap W$ have finite perimeter. Hence we can apply the divergence theorem to both sets. Thus we get

$$\int_{E \setminus S_\theta} \operatorname{div} \xi \, dx = \int_{\partial^*((E \setminus S_\theta) \cap V)} \xi \cdot \nu \, dx + \int_{\partial^*((E \setminus S_\theta) \cap W)} \xi \cdot \nu \, dx. \quad (66)$$

On the other hand, we may apply the divergence theorem in $S_\theta \setminus E$, since $S_\theta \setminus E \subset V$ and ξ is Lipschitz continuous in V . Using the formula for the reduced boundary of the difference of two sets of finite perimeter (see [13, Theorem 16.3]), conditions (iv) and (v),

and inequality (65), together with (66) (and the analog for $E \setminus S_\theta$), yields

$$\begin{aligned}
& \int_{\partial S_\theta \setminus (E^{(1)} \cup \partial^* E \cup \mathbb{C})} \xi \cdot \nu_{S_\theta} d\mathcal{H}^2 - \int_{(\partial S_\theta \setminus \partial^* E) \cap \mathbb{C}} \xi \cdot \nu_{\mathbb{C}} d\mathcal{H}^2 \\
& \quad - \int_{\partial^* E \cap S_\theta} \xi \cdot \nu_E d\mathcal{H}^2 + \mathcal{H}^2(\partial S_\theta \cap \partial^* E \cap \{v_E = -v_{S_\theta}\}) \\
& \leq \int_{(\partial^* E \cap \bar{V}) \setminus (\bar{S}_\theta \cup \Sigma_0)} \xi \cdot \nu_E d\mathcal{H}^2 - \int_{\partial S_\theta \cap E^{(1)}} \xi \cdot \nu_{S_\theta} d\mathcal{H}^2 \\
& \quad + \int_{E^{(1)} \cap \Sigma_0} \nu_{\Sigma_0} \cdot \xi|_V d\mathcal{H}^2 + \mathcal{H}^2(\partial^* E \cap \Sigma_0) - \int_{E^{(1)} \cap \Sigma_0} \nu_{\Sigma_0} \cdot \xi|_W d\mathcal{H}^2 \\
& \quad + \int_{(\partial^* E \cap \bar{W}) \setminus (\mathbb{C} \cup \Sigma_0)} \xi \cdot \nu_E d\mathcal{H}^2 - \int_{(\partial^* E \setminus \partial S_\theta) \cap \mathbb{C}} \xi \cdot \nu_{\mathbb{C}} d\mathcal{H}^2 \\
& \quad - \mathcal{H}^2(\partial S_\theta \cap \partial^* E \cap \{v_E = -v_{S_\theta}\}). \tag{67}
\end{aligned}$$

Under the weaker assumption (i), it is enough to observe that the divergence theorem can be applied in $V \setminus (\gamma)_\delta$ and in $W \setminus (\gamma)_\delta$, and that the boundary contribution on $\partial(\gamma)_\delta$ vanishes as $\delta \rightarrow 0^+$ due to assumption (v) and to the fact that $\mathcal{H}^2(\partial(\gamma)_\delta) \rightarrow 0$ as $\delta \rightarrow 0^+$. Therefore, we get the same inequality as above.

Neglecting the term $\mathcal{H}^2(\partial S_\theta \cap \partial^* E \cap \{v_E = -v_{S_\theta}\})$ in both sides of (67), rearranging and suitably combining the remaining terms, and observing that $\partial^* E \cap S_\theta = \partial^* E \cap S_\theta \cap V$, we get

$$\begin{aligned}
& \int_{(\partial S_\theta \setminus \partial^* E) \setminus \mathbb{C}} \xi \cdot \nu_{S_\theta} d\mathcal{H}^2 - \int_{(\partial S_\theta \setminus \partial^* E) \cap \mathbb{C}} \xi \cdot \nu_{\mathbb{C}} d\mathcal{H}^2 \\
& \leq \int_{(\partial^* E \cap \bar{V}) \setminus (\partial S_\theta \cup \Sigma_0)} \xi \cdot \nu_E d\mathcal{H}^2 + \int_{(\partial^* E \cap \bar{W}) \setminus (\mathbb{C} \cup \Sigma_0)} \xi \cdot \nu_E d\mathcal{H}^2 \\
& \quad + \mathcal{H}^2(\partial^* E \cap \Sigma_0) - \int_{(\partial^* E \setminus \partial S_\theta) \cap \mathbb{C}} \xi \cdot \nu_{\mathbb{C}} d\mathcal{H}^2 \\
& \quad + \int_{E^{(1)} \cap \Sigma_0} \nu_{\Sigma_0} \cdot \xi|_V d\mathcal{H}^2 - \int_{E^{(1)} \cap \Sigma_0} \nu_{\Sigma_0} \cdot \xi|_W d\mathcal{H}^2 \\
& \leq \int_{(\partial^* E \cap \bar{V}) \setminus (\partial S_\theta \cup \Sigma_0)} \xi \cdot \nu_E d\mathcal{H}^2 + \int_{(\partial^* E \cap \bar{W}) \setminus (\mathbb{C} \cup \Sigma_0)} \xi \cdot \nu_E d\mathcal{H}^2 \\
& \quad + \mathcal{H}^2(\partial^* E \cap \Sigma_0) - \int_{(\partial^* E \setminus \partial S_\theta) \cap \mathbb{C}} \xi \cdot \nu_{\mathbb{C}} d\mathcal{H}^2, \tag{68}
\end{aligned}$$

where the last inequality follows from assumption (iii). Using assumptions (iv) and (v), we may now estimate

$$\begin{aligned}
J_\lambda(S_\theta) - J_\lambda(E) &= \mathcal{H}^2((\partial S_\theta \setminus \partial^* E) \setminus \mathbb{C}) - \mathcal{H}^2((\partial^* E \setminus \partial S_\theta) \setminus \mathbb{C}) \\
&\quad - \lambda[\mathcal{H}^2((\partial S_\theta \setminus \partial^* E) \cap \mathbb{C}) - \mathcal{H}^2((\partial^* E \setminus \partial S_\theta) \cap \mathbb{C})]
\end{aligned}$$

$$\begin{aligned}
 &\leq \int_{(\partial S_\theta \setminus \partial^* E) \setminus \mathbb{C}} \xi \cdot \nu_{S_\theta} d\mathcal{H}^2 - \int_{(\partial^* E \cap \bar{V}) \setminus (\partial S_\theta \cup \Sigma_0)} \xi \cdot \nu_E d\mathcal{H}^2 \\
 &\quad - \int_{(\partial^* E \cap \bar{W}) \setminus (\mathbb{C} \cup \Sigma_0)} \xi \cdot \nu_E d\mathcal{H}^2 - \mathcal{H}^2(\partial^* E \cap \Sigma_0) \\
 &\quad - \int_{(\partial S_\theta \setminus \partial^* E) \cap \mathbb{C}} \xi \cdot \nu_{\mathbb{C}} d\mathcal{H}^2 + \int_{(\partial^* E \setminus \partial S_\theta) \cap \mathbb{C}} \xi \cdot \nu_{\mathbb{C}} d\mathcal{H}^2 \\
 &\quad - \int_{(\partial S_\theta \setminus \partial^* E) \cap \mathbb{C}} (\lambda - \xi \cdot \nu_{\mathbb{C}}) d\mathcal{H}^2 + \int_{(\partial^* E \setminus \partial S_\theta) \cap \mathbb{C}} (\lambda - \xi \cdot \nu_{\mathbb{C}}) d\mathcal{H}^2 \\
 &\leq - \int_{(\partial S_\theta \setminus \partial^* E) \cap \mathbb{C}} (\lambda - \xi \cdot \nu_{\mathbb{C}}) d\mathcal{H}^2 + \int_{(\partial^* E \setminus \partial S_\theta) \cap \mathbb{C}} (\lambda - \xi \cdot \nu_{\mathbb{C}}) d\mathcal{H}^2 \\
 &=: -I_1 + I_2, \tag{69}
 \end{aligned}$$

where the last inequality follows from (68). Observe that by (vi)₁ and by (62),

$$\lambda - \xi \cdot \nu_{\mathbb{C}} \geq 0 \quad \text{in } (\partial S_\theta \setminus \partial^* E) \cap \mathbb{C}.$$

In particular, $-I_1 \leq 0$. On the other hand, by (vi)₂,

$$\lambda - \xi \cdot \nu_{\mathbb{C}} \leq 0 \quad \text{on } (\partial^* E \setminus \partial S_\theta) \cap \mathbb{C}.$$

Thus, also $I_2 \leq 0$ and this concludes the proof of (61).

Now assume $J_\lambda(E) = J_\lambda(S_\theta)$. Then from (69) we have

$$\int_{(\partial S_\theta \setminus \partial^* E) \cap \mathbb{C}} (\lambda - \xi \cdot \nu_{\mathbb{C}}) d\mathcal{H}^2 = \int_{(\partial^* E \setminus \partial S_\theta) \cap \mathbb{C}} (\lambda - \xi \cdot \nu_{\mathbb{C}}) d\mathcal{H}^2 = 0.$$

Thus, if the second inequality in (vi) is strict, we have

$$\mathcal{H}^2((\partial^* E \setminus \partial S_\theta) \cap \mathbb{C}) = 0. \tag{70}$$

In turn, again (69) implies that

$$\xi|_W = \nu_E, \quad \mathcal{H}^2\text{-a.e. on } \partial^* E \cap W. \tag{71}$$

Now observe that by assumption, for all $(x', t) \in W$,

$$\xi|_W(x', t) \cdot (x', 0) \geq 0 \tag{72}$$

in W . Writing $\chi_E = \chi_E(\varrho, \theta, t)$, where (ϱ, θ, t) denotes the cylindrical coordinates, and setting $e_\varrho = (\cos \theta, \sin \theta, 0)$, we have that

$$D_\varrho \chi_E = -\nu_E \cdot e_\varrho \mathcal{H}^2 \llcorner \partial^* E.$$

Thus, thanks to (71) and (72), $D_\varrho \chi_E$ is a nonpositive measure in W . In turn, by (64) it follows that the function $\chi_E(\cdot, \theta, t)$ is nonincreasing. This fact, together with (70), implies that χ_E is identically zero in W , and thus $E \subset \mathcal{H}$. The conclusion then follows by Theorem 4.1. \blacksquare

Remark A.2. A careful inspection of the first part of the proof of Lemma A.1 yields the same minimality property also in the case where $\Sigma_0 \cap \partial S_\theta \neq \emptyset$, provided ξ is continuous along Σ_0 .

In the constructions of Section 4 we used the foliating properties of solutions to the equation

$$-\left(\frac{gg'}{\sqrt{1+g'^2}}\right)' + \sqrt{1+g'^2} = Hg, \quad (73)$$

where H is a fixed constant, when we vary both the initial point and the initial value of the solution.

Note that the differential equation above can be rewritten as

$$-\frac{g''}{(1+g'^2)^{3/2}} + \frac{1}{g\sqrt{1+g'^2}} = H.$$

Remark A.3. Note that the differential equation in (73) is the Euler–Lagrange equation of the functional

$$\mathcal{I}(g; I) := 2\pi \int_I g \sqrt{1+g'^2} dt - H\pi \int_I g^2 dt. \quad (74)$$

Moreover, if $g \geq 0$, then

$$\mathcal{I}(g; I) = P(E_g, \{(x', t) : t \in I\}) - H|E_g \cap \{(x', t) : t \in I\}|, \quad (75)$$

where $E_g \subset \mathbb{R}^3$ is the axially symmetric set generated by the rotation of the subgraph of g around the vertical t -axis, and $P(E, \Omega)$ denotes the perimeter of E relative to the open set Ω . It follows, in particular, that $\partial E_g \cap \{(x', t) : t \in I\}$ has constant mean curvature equal to H .

Lemma A.4. Let $H > 0$, let $f : \mathbb{R} \rightarrow (0, +\infty)$ be a smooth function, and let $b \in \mathbb{R}$ be such that

$$f'(\sigma) \neq b \quad \text{for all } \sigma \in \mathbb{R}. \quad (76)$$

Then, for every open and bounded interval $I = (\alpha, \beta)$ there exists $\bar{\eta} > 0$ such that for every $\sigma \in I$, the solution $g(\sigma, \cdot)$ of the problem

$$\begin{cases} -\left(\frac{gg'}{\sqrt{1+g'^2}}\right)' + \sqrt{1+g'^2} = Hg, \\ g > 0 \\ g(\sigma) = f(\sigma), \quad g'(\sigma) = b, \end{cases} \quad \text{in } (\sigma - \bar{\eta}, \sigma + \bar{\eta}) \quad (77)$$

exists and is unique in $(\sigma - \bar{\eta}, \sigma + \bar{\eta})$. Moreover, the graphs of the family $(g(\sigma, \cdot))_{\sigma \in (\alpha, \beta)}$ foliate an open set containing $\{(\sigma, f(\sigma)) : \sigma \in (\alpha, \beta)\}$.

Proof. Fix $\sigma_0 \in [\alpha, \beta]$. Since $f(\sigma_0) > 0$, there exists $t' > 0$ such that the solution $g(\sigma_0, \cdot)$ to (77) exists and is unique in $(\sigma_0 - t', \sigma_0 + t')$. We may now apply standard results on the smooth dependence from the initial data to deduce that there exists $0 < \eta < t'$, sufficiently small, such that for every $\sigma \in (\sigma_0 - \eta, \sigma_0 + \eta)$ the solution $g(\sigma, \cdot)$ of (77) exists and is unique in $(\sigma_0 - \eta, \sigma_0 + \eta)$.

Consider the map $\Phi: (\sigma_0 - \eta, \sigma_0 + \eta) \times (\sigma_0 - \eta, \sigma_0 + \eta) \rightarrow \mathbb{R}^2$, $\Phi(t, \sigma) := (t, g(\sigma, t))$. We claim that, by taking η smaller if needed, Φ is injective. By the inverse function theorem, the claim follows by observing that

$$D\Phi(\sigma_0, \sigma_0) = \begin{pmatrix} 1 & 0 \\ b & f'(\sigma_0) - b \end{pmatrix},$$

which is invertible thanks to (76). Therefore, the family $(g(\sigma, \cdot))_{\sigma \in (\sigma_0 - \eta, \sigma_0 + \eta)}$ foliates a neighborhood of $\{(\sigma, f(\sigma)) : \sigma \in (\sigma_0 - \eta, \sigma_0 + \eta)\}$. The conclusion then follows by a covering argument. ■

The proofs of Theorems 4.10 and 4.11 are based on the following construction of rotationally symmetric surfaces with constant mean curvature. Given $H > 0$, $a > 0$, and $\delta \in \mathbb{R}$, for every $b \in \mathbb{R}$ we denote by $g_{a,b}^\delta \in C^2(t_{\delta;a,b}^-, t_{\delta;a,b}^+)$, with $\delta \in (t_{\delta;a,b}^-, t_{\delta;a,b}^+)$, the maximal solution to

$$\begin{cases} -\left(\frac{gg'}{\sqrt{1+g'^2}}\right)' + \sqrt{1+g'^2} = Hg & \text{in } (t_{\delta;a,b}^-, t_{\delta;a,b}^+), \\ g > 0 & \text{in } (t_{\delta;a,b}^-, t_{\delta;a,b}^+), \\ g(\delta) = a, \quad g'(\delta) = b. \end{cases} \quad (78)$$

For $\theta \in (0, \pi)$, let

$$g_\theta(t) := \sqrt{\frac{4}{H^2} - \left(t + \frac{2}{H} \cos \theta\right)^2}, \quad t \in \left(-\frac{2}{H}(1 + \cos \theta), \frac{2}{H}(1 - \cos \theta)\right), \quad (79)$$

and note that g_θ describes the radial profile of the spherical cap (see (32))

$$S_{\cos \theta, \frac{2}{H}} = B\left(-\frac{2}{H} \cos \theta e_3, \frac{2}{H}\right) \cap \{(x', t) : t > 0\},$$

and thus, in particular, solves the differential equation in (78).

Lemma A.5. *Fix $H > 0$ and let*

$$D := \{(\delta, \theta) : \theta \in [\frac{\pi}{2}, \pi) \text{ and } \delta \in (-\frac{2}{H}(1 + \cos \theta), -\frac{2}{H} \cos \theta)\}.$$

There exists a lower semicontinuous function $t: D \rightarrow (0, +\infty)$, satisfying

$$-\frac{2}{H} \cos \theta < t(\delta, \theta) \leq \frac{2}{H}(1 - \cos \theta) \quad (80)$$

with the following properties: for every $\theta \in [\frac{\pi}{2}, \pi)$ and for every $\delta < t_0 < t_1 < t(\delta, \theta)$ there exists $\varepsilon > 0$ such that if $b \in [g'_\theta(\delta) - \varepsilon, g'_\theta(\delta) + \varepsilon]$, and $a = g_\theta(\delta)$, then the solution $g_{a,b}^\delta$ to (78) exists and is strictly positive in $[\delta, t_1]$ and the graphs of $(g_{a,b}^\delta)_{b \in (g'_\theta(\delta) - \varepsilon, g'_\theta(\delta) + \varepsilon)}$ foliate the open set

$$U := \{(t, u) : t \in (t_0, t_1), g_{a, g'_\theta(\delta) - \varepsilon}^\delta(t) < u < g_{a, g'_\theta(\delta) + \varepsilon}^\delta(t)\},$$

and thus, in particular, an open neighborhood of the graph of $g_\theta|_{(t_0, t_1)}$. Finally,

$$t\left(0, \frac{\pi}{2}\right) = \frac{2}{H}, \quad \lim_{(\delta, \theta) \rightarrow (0, \frac{\pi}{2})} t(\delta, \theta) = \frac{2}{H}. \quad (81)$$

Proof. Set $J := (-2(1 + \cos \theta)/H, 2(1 - \cos \theta)/H)$. For $\theta \in [\frac{\pi}{2}, \pi)$ and $I \subset J$, we denote by $\mathcal{I}''(g_\theta; I)$ the second variation of (74) evaluated at g_θ , restricted to $H_0^1(I)$.

Given a set E of finite perimeter and an open set Ω , we define

$$\mathcal{F}(E; \Omega) := P(E; \Omega) - H|E \cap \Omega|.$$

We now recall the second variation formula for a smooth critical point E of the above functional: given a smooth vector field X with $\text{supp } X \subset\subset \Omega$, and denoting by $\Phi(\eta, x)$ the associated flow, which satisfies

$$\begin{cases} \frac{\partial \Phi}{\partial \eta} = X(\Phi), \\ \Phi(0, x) = x, \end{cases}$$

we have

$$\begin{aligned} \frac{d^2}{d\eta^2} \mathcal{F}(\Phi(\eta, E); \Omega)|_{\eta=0} &= \int_{\partial E} (|\nabla_\tau(X \cdot \nu_E)|^2 - |B_{\partial E}|^2(X \cdot \nu_E)^2) d\mathcal{H}^2 \\ &=: \partial^2 \mathcal{F}(E; \Omega)[X \cdot \nu_E], \end{aligned}$$

where $B_{\partial E}$ is the second fundamental form and thus $|B_{\partial E}|^2$ is equal to the sum of the squares of the principal curvatures of ∂E . Indeed, this formula can be obtained by combining the second variation formula for the perimeter functional (see for instance [1, Theorem 3.1], with $\gamma = 0$), with the second variation formula for the volume (see for instance [5, formula (2.30)]).

For every $t \in (\delta, 2(1 - \cos \theta)/H)$ and for every $\varphi \in C_c^\infty(\delta, t)$ let $X(x', s) := \varphi(s)(x'/|x'|, 0)$, $s \in (\delta, t)$. Then the associated flow is given by $\Phi(\eta, (x', s)) = (x', s) + \eta\varphi(s)(x'/|x'|, 0)$. In turn, from (75) one can readily check that

$$\mathcal{I}(g_\theta + \eta\varphi; (\delta, t)) = \mathcal{F}(\Phi(\eta, E_{g_\theta}); \mathbb{R}^2 \times (\delta, t))$$

for every $\eta \in \mathbb{R}$. Thus

$$\mathcal{I}''(g_\theta; (\delta, t))[\varphi] = \partial^2 \mathcal{F}(E_{g_\theta}; \mathbb{R}^2 \times (\delta, t))[X \cdot \nu_{E_{g_\theta}}] = \partial^2 \mathcal{F}(E_{g_\theta}; \mathbb{R}^2 \times (\delta, t))[\psi], \quad (82)$$

where $\psi(s) := \varphi(s)\sqrt{1 - (Hs/2 + \cos\theta)^2}$. A straightforward calculation, using either (82) or the explicit expression of \mathcal{I} , shows that for any $\varphi \in H_0^1(I)$ we have

$$\begin{aligned} \mathcal{I}''(g_\theta; I)[\varphi] &= 2\pi \int_I \left(\frac{g_\theta \varphi'^2}{(1 + g_\theta'^2)^{3/2}} + \frac{2g_\theta' \varphi \varphi'}{(1 + g_\theta'^2)^{1/2}} - H\varphi^2 \right) ds \\ &= 2\pi \int_I \left(\frac{g_\theta \varphi'^2}{(1 + g_\theta'^2)^{3/2}} - \left[\left(\frac{g_\theta'}{(1 + g_\theta'^2)^{1/2}} \right)' + H \right] \varphi^2 \right) ds \\ &= 2\pi \int_I \left(\frac{2}{H} \left[1 - \left(\frac{sH}{2} + \cos\theta \right)^2 \right]^2 \varphi'^2 - \frac{H}{2} \varphi^2 \right) ds, \end{aligned} \quad (83)$$

where in the last equality we used (79). For $(\delta, \theta) \in (-\frac{2}{H}(1 + \cos\theta), -\frac{2}{H}\cos\theta) \times [\frac{\pi}{2}, \pi)$ we set

$$\begin{aligned} t(\delta, \theta) &:= \sup \{ t \in (\delta, 2(1 - \cos\theta)/H) : \mathcal{I}''(g_\theta; (\delta, t))[\varphi] > 0 \\ &\quad \text{for all } \varphi \in H_0^1(\delta, t) \setminus \{0\} \}. \end{aligned} \quad (84)$$

Observe that the above sup is well defined. Indeed, since $\delta > -\frac{2}{H}(1 + \cos\theta)$, the coefficient of φ'^2 in the last integral in (83) is greater than a strictly positive constant $c_0(\delta)$. Therefore, by the Poincaré inequality on intervals,

$$\mathcal{I}''(g_\theta; (\delta, t))[\varphi] \geq 2\pi \int_\delta^t \left(c_0(\delta) \varphi'^2 - \frac{H}{2} \varphi^2 \right) ds \geq 2\pi \int_\delta^t \left(\frac{4\pi c_0(\delta)}{(t - \delta)^2} - \frac{H}{2} \right) \varphi^2 ds > 0$$

provided $t - \delta$ is sufficiently small.

Let $(\delta_n, \theta_n) \rightarrow (\delta, \theta)$. If $\delta < t < t(\delta, \theta)$, then

$$\min \{ \mathcal{I}''(g_{\theta_n}; (\delta, t))[\varphi] : \varphi \in H_0^1(\delta, t), \|\varphi\|_{L^2} = 1 \} =: m > 0. \quad (85)$$

For every n we denote by φ_n a minimizer of the above problem, with δ, θ replaced by δ_n, θ_n , respectively. Since $\{\varphi_n\}$ is bounded in $H_0^1(J)$, we may assume that, up to a (not relabeled) subsequence, $\varphi_n \rightharpoonup \varphi$ in $H_0^1(J)$, with $\varphi \in H_0^1(\delta, t)$ and $\|\varphi\|_{L^2} = 1$. Recalling the explicit expression (83), and by standard arguments, one may check that

$$\liminf_n \mathcal{I}''(g_{\theta_n}; (\delta_n, t))[\varphi_n] \geq \mathcal{I}''(g_\theta; (\delta, t))[\varphi] \geq m, \quad (86)$$

which implies that for n large enough, $t(\delta_n, \theta_n) \geq t$. This implies the lower semicontinuity of $t(\cdot, \cdot)$.

It is well known that the smallest eigenvalue of the Laplace–Beltrami operator on the hemisphere of radius R is given by $2/R^2$; see for instance the proof of [12, Proposition 2.1.13].² Thus if E is a ball and Ω is an open set such that $\partial E \cap \Omega$ is a proper subset

²One way to see this is to observe that the odd reflection with respect to the horizontal plane of any eigenfunction on the hemisphere $S_{\pi/2}$ is an eigenfunction on the sphere. Thus the first eigenfunction is the first spherical harmonic vanishing on the equator, that is, the function $u(x', t) = t$

of an open hemisphere, then by the strict monotonicity with respect to set inclusion of the first eigenvalue $\lambda_1(\cdot)$ of the Laplace–Beltrami operator, we have that $\lambda_1(\partial E \cap \Omega) > 2/R^2$. In turn, this implies that for every $\varphi \in H_0^1(\partial E \cap \Omega)$,

$$\int_{\partial E \cap \Omega} |\nabla_\tau \varphi|^2 d\mathcal{H}^2 \geq \lambda_1 \int_{\partial E \cap \Omega} \varphi^2 d\mathcal{H}^2 > \frac{2}{R^2} \int_{\partial E \cap \Omega} \varphi^2 d\mathcal{H}^2,$$

that is, $\partial^2 \mathcal{F}(E; \Omega)$ is positive definite on $H_0^1(\partial E \cap \Omega)$. From this property and (82), it then follows that if $\theta = \pi/2$,

$$\mathcal{I}''(g_{\pi/2}; (0, 2/H))[\varphi] > 0$$

for all $\varphi \in C_c^\infty(0, 2/H) \setminus \{0\}$. Recalling (84), this shows the first equality in (81), while the second one now follows from the lower semicontinuity of $t(\cdot, \cdot)$. The strict stability of proper subsets of hemispheres implies that $\mathcal{I}''(g_\theta; (\delta, -\frac{2}{H} \cos \theta))$ is positive definite. Now denote by $m(t)$ the minimum in (85) (for δ and θ fixed). An argument entirely similar to the one used to prove (86) shows that the function $m(\cdot)$ is lower semicontinuous. Hence, $m(t) > 0$ for t sufficiently close to $-\frac{2}{H} \cos \theta$, thus proving the first inequality in (80).

Observe now that since $g_\theta > 0$ in $[\delta, t(\delta, \theta))$, for any fixed $\delta < t_1 < t(\delta, \theta)$ there exists $\varepsilon > 0$ such that the solutions $g_{a,b}^\delta$ to (78) with $a = g_\theta(\delta)$ and $b \in [g'_\theta(\delta) - \varepsilon, g'_\theta(\delta) + \varepsilon]$, are defined and satisfy $g_{a,b}^\delta > 0$ in $[\delta, t_1]$.

Recalling now that $\mathcal{I}''(g_\theta; (\delta, t(\delta, \theta)))$ is positive semidefinite, by [10, Section 26–Theorem 2'] there are no conjugate points in $(\delta, t(\delta, \theta))$. Then, by well-known properties, we may conclude that the family $(g_{a,b}^\delta)_{b \in (g'_\theta(\delta) - \varepsilon, g'_\theta(\delta) + \varepsilon)}$ is foliating, by taking ε smaller if needed. For the reader's convenience we briefly recall the argument. We start by showing that

$$f(t) := \frac{\partial g_{a,b}^\delta(t)}{\partial b} \Big|_{b=g'_\theta(\delta)} \neq 0 \quad \text{for all } t \in (\delta, t(\delta, \theta)). \quad (87)$$

To this aim observe that f is a solution of the Euler–Lagrange equation of $\mathcal{I}''(g_\theta; (\delta, t(\delta, \theta)))$ in the interval $(\delta, t(\delta, \theta))$, or equivalently, of the linearization of (78). Moreover, $f(\delta) = 0$ and

$$f'(\delta) = \frac{\partial}{\partial b} ((g_{a,b}^\delta)'(\delta)) \Big|_{b=g'_\theta(\delta)} = 1,$$

and thus $f \neq 0$ in a right neighborhood of δ . Suppose now by contradiction that there exists a point $\bar{t} \in (\delta, t(\delta, \theta))$ at which f vanishes. But then by the previous observations it follows that \bar{t} is a conjugate point, which is impossible. Once (87) is established, the foliating property of the family $(g_{a,b}^\delta)_{b \in (g'_\theta(\delta) - \varepsilon, g'_\theta(\delta) + \varepsilon)}$ restricted to any interval $I \subset\subset (\delta, t(\delta, \theta))$ for ε sufficiently small follows from an application of the implicit function theorem (see for instance [3, p. 79]). ■

Funding. The research of I. Fonseca was partially funded by the National Science Foundation under grants DMS-1411646 and DMS-1906238. The research of N. Fusco and M. Morini was partially supported by MUR PRIN project 2017TEXA3H. The research of

G. Leoni was partially supported by the NSF grants DMS-1714098 and DMS-2108784. The research of M. Morini was partially supported by GNAMPA and by the University of Parma via the project “Regularity, Nonlinear Potential Theory and related topics”.

References

- [1] E. Acerbi, N. Fusco, and M. Morini, Minimality via second variation for a nonlocal isoperimetric problem. *Comm. Math. Phys.* **322** (2013), no. 2, 515–557 Zbl [1270.49043](#) MR [3077924](#)
- [2] L. Ambrosio, N. Fusco, and D. Pallara, *Functions of bounded variation and free discontinuity problems*. Oxford Math. Monogr., The Clarendon Press, Oxford University Press, New York, 2000 Zbl [0957.49001](#) MR [1857292](#)
- [3] O. Bolza, *Lectures on the calculus of variations*. Chelsea Publishing, New York, 1961 Zbl [0098.07301](#) MR [0123206](#)
- [4] J. Choe, M. Ghomi, and M. Ritoré, The relative isoperimetric inequality outside convex domains in \mathbf{R}^n . *Calc. Var. Partial Differential Equations* **29** (2007), no. 4, 421–429 MR [2329803](#)
- [5] R. Choksi and P. Sternberg, On the first and second variations of a nonlocal isoperimetric problem. *J. Reine Angew. Math.* **611** (2007), 75–108 Zbl [1132.35029](#) MR [2360604](#)
- [6] N. P. Dasgupta, J. Sun, C. Liu, S. Brittman, S. C. Andrews, J. Lim, H. Gao, R. Yan, and P. Yang, 25th anniversary article: semiconductor nanowires—synthesis, characterization, and applications. *Adv. Mater.* **26** (2014), no. 4, 2137–2184 MR [2329803](#)
- [7] G. De Philippis and F. Maggi, Regularity of free boundaries in anisotropic capillarity problems and the validity of Young’s law. *Arch. Ration. Mech. Anal.* **216** (2015), no. 2, 473–568 Zbl [1321.35158](#) MR [3317808](#)
- [8] L. Esposito and N. Fusco, A remark on a free interface problem with volume constraint. *J. Convex Anal.* **18** (2011), no. 2, 417–426 Zbl [1216.49033](#) MR [2828497](#)
- [9] N. Fusco and M. Morini, Total positive curvature and the equality case in the relative isoperimetric inequality outside convex domains. 2021, arXiv:[2103.03299](#)
- [10] I. M. Gelfand and S. V. Fomin, *Calculus of variations*. Prentice-Hall, Englewood Cliffs, NJ, 1963 Zbl [0127.05402](#) MR [0160139](#)
- [11] A. Golovin, S. H. Davis, and S. H. Voorhees, Step-flow growth of a nanowire in the vapor-liquid-solid and vapor-solid-solid processes. *J. Appl. Phys.* **104** (2008), Article ID 074301
- [12] R. López, *Constant mean curvature surfaces with boundary*. Springer Monogr. Math., Springer, Heidelberg, 2013 Zbl [1278.53001](#) MR [3098467](#)
- [13] F. Maggi, *Sets of finite perimeter and geometric variational problems*. Camb. Stud. Adv. Math. 135, Cambridge University Press, Cambridge, 2012 Zbl [1255.49074](#) MR [2976521](#)
- [14] M. Morini, M. Ponsiglione, and E. Spadaro, Long time behavior of discrete volume preserving mean curvature flows. *J. Reine Angew. Math.* **784** (2022), 27–51 Zbl [07502522](#) MR [4388339](#)
- [15] S. Muralidharan, P. W. Voorhees, and S. H. Davis, Nonaxisymmetric droplet unpinning in vapor-liquid-solid-grown nanowires. *J. Appl. Phys.* **114** (2013), Article ID 114305
- [16] J. F. Oliver, C. Huh, and S. G. Mason, Resistance to spreading of liquids by sharp edges. *J. Colloid Interface Sci.* **59** (1977), 568–581
- [17] S. Roper, A. Anderson, S. H. Davis, and P. W. Voorhees, Radius selection and droplet unpinning in vapor-liquid-solid-grown nanowires. *J. Appl. Phys.* **107** (2010), Article ID 114320

- [18] S. M. Roper, S. H. Davis, S. A. Norris, A. A. Golovin, and P. W. Voorhees, Steady growth of nanowires via the vapor-liquid-solid method. *J. Appl. Phys.* **102** (2007), Article ID 034304
- [19] E. J. Schwalbach, S. H. Davis, P. W. Voorhees, J. A. Warren, and D. Wheeler, Stability and topological transformations of liquid droplets on vapor-liquid-solid nanowires. *J. Appl. Phys.* **111** (2012), Article ID 024302
- [20] K. Schwarz and J. Tersoff, From droplets to nanowires: Dynamics of vapor-liquid-solid growth. *Phys. Rev. Lett.* **102** (2009), Article ID 206101
- [21] J. E. Taylor, Boundary regularity for solutions to various capillarity and free boundary problems. *Comm. Partial Differential Equations* **2** (1977), no. 4, 323–357 Zbl [0357.35010](#) MR [487721](#)
- [22] B. Tian, T. J. Kempa, and C. M. Lieber, Single nanowire photovoltaics. *Chem. Soc. Rev.* **38** (2009), 16–24
- [23] S. Vincini, *Existence of generalized minimizers for the capillarity energy outside convex sets*. Master’s thesis, University of Parma, 2021
- [24] R. Wagner and W. Ellis, Vapor-liquid-solid mechanism of single crystal growth. *Appl. Phys. Lett.* **4** (1964), 89–90

Received 5 August 2021; revised 10 January 2022; accepted 24 January 2022.

Irene Fonseca

Department of Mathematical Sciences, Carnegie Mellon University, 5000 Forbes Avenue, Pittsburgh, PA 15213, USA; fonseca@andrew.cmu.edu

Nicola Fusco

Dipartimento di Matematica e Applicazioni, Università degli Studi di Napoli “Federico II”, via Cintia Complesso Universitario di Monte S. Angelo, 80126 Napoli, Italy; n.fusco@unina.it

Giovanni Leoni

Department of Mathematical Sciences, Carnegie Mellon University, 5000 Forbes Avenue, Pittsburgh, PA 15213, USA; giovanni@andrew.cmu.edu

Massimiliano Morini

Dipartimento di Scienze Matematiche, Fisiche e Informatiche, Università degli Studi di Parma, Parco Area delle Scienze 53/a, 43124 Parma, Italy; massimiliano.morini@unipr.it